

# Inpal

Energie



## Polyuretub 130

Pre-insulated pipe system

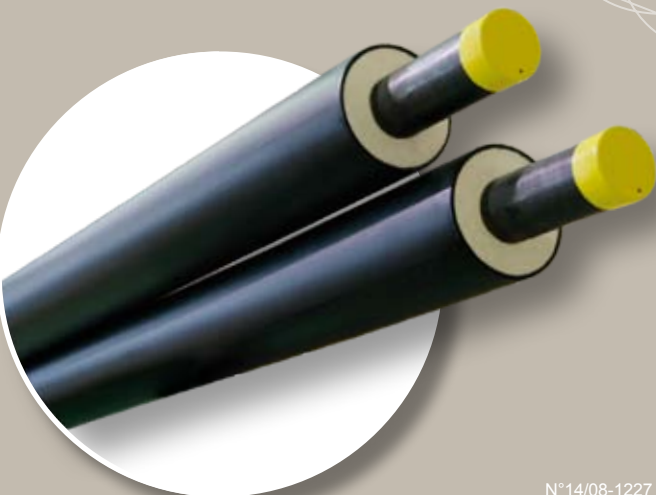

N°14/08-1227



This catalogue presents design offices and project engineers with the information about Inpal Energie's pre-insulated pipes needed to draw up purchase and installation specifications with the aim of designing the most efficient and profitable network possible .

This information may be modified at any time without prior notice depending on the results of current research aimed at improving the quality of our products.

The instructions or recommendations set out in this catalogue in no way modify or cancel the terms of Inpal Energie's general sales terms and conditions. Network design and assembly must be done by an experienced design office and installer respectively, according to professional standards, in order to optimise its lifetime and profitability.

Furthermore, the installer and the operator remain fully and entirely responsible for the correct operation of the network and for the compatibility of Inpal Energie's products with the specific operating conditions.

# Contents

---

## Inpal Energie

---

5

- 6 The company
- 7 Product ranges
- 8 Our sites
- 9 References
- 10 Quality
- 11 Environment



## Technical data

---

13

- 14 Insulation range
- 15 Straight pipes
- 16 Bends
- 18 Tee branches
- 24 Anchors
- 25 Bellows
- 26 Reductions
- 27 Valves
- 30 Injected junction kits
- 36 Half-shell junction kits
- 38 Other accessories
- 44 Monitoring Systems
- 46 Geolocation systems



## References

---

49

- 50 Zona Franca - Barcelona
- 51 Expo'98 - Lisbon
- 52 La Thuile - Italy
- 53 Climespace - Paris
- 54 London Olympic Site
- 55 22@ - Barcelona
- 56 Antwerp - Belgium







# Inpal Energie

- 6 The company
- 7 Product ranges
- 8 Our sites
- 9 References
- 10 Quality
- 11 Environment

## The company

**Inpal Energie** is a subsidiary of the SOLICE group with 160 employees.

The SOLICE group is specialised in network engineering, and the manufacture and installation of pre-insulated pipes and accessories for the transportation of fluids used for district heating and cooling networks.

INPAL Energie is today the market leader in France and a key player in the European market for pre-insulated pipes thanks to the solutions it provides to both users and investors.

With **30 years of expertise**, and over **15,000 km of piping laid**, INPAL Energie puts its know-how into action with the aim of reducing energy consumption.

Inpal Energie's offer consists of:

- Network design
- Supply of pre-insulated pipes and accessories
- Insulation of fittings and junctions on site

**Inpal Energie** works with local councils, energy service providers, and network installers.

Changing demographics, the depletion of the world's oil resources and resulting increases in petrol prices and strict legislation on carbon emissions have all contributed to the vital need to find economically viable solutions for reducing CO2 emissions.

In response to these very immediate challenges, many countries have adopted new environmental policies to combat climate change.

Inpal Energy's activity plays a role in meeting this key challenge for the 21st century.





# Product ranges

Our three main products cover a broad temperature range to offer a customised solution for every project :

+ 450 °C



## STEEL-IN-STEEL PIPE: TUCAL

Fluid or steam transport system  
Temperatures: **From - 60°C to 450 °C**  
Diameter: **ND 20 to ND 500**  
Applications: industry, steam



## RIGID PIPE: POLYURETUB 130

Fluid transport system  
Temperatures: **From - 50°C to 148 °C**  
Diameter: **ND 20 to ND 1000**  
Applications: district heating and chilled water networks



## FLEXIBLE PIPES: ISOPAL

Fluid transport system  
Temperatures: **From 5°C to 95 °C**  
Temperatures: Diameter: **ND 25 to ND 110**  
Applications: heating networks, cold water, HWS  
Single or double carrier pipe

- 60 °C

## Our Sites

**Inpal Energie** is supported by a sales force based in 7 sales offices across France and to date has 4 subsidiaries in Spain, Italy, Germany and the United Kingdom.

**Inpal Energie** also has operations in Switzerland, Belgium, the Netherlands, Luxemburg and all over the world.



### Local sales offices:

- Ile-de-France
- North
- West
- East
- Rhône-Alpes
- South-East
- Midi-Pyrenees
- Switzerland/Benelux



### Subsidiaries:

- Spain: Inpal Energía - Barcelona
- Italy: Inpal Energia - Torino
- Germany: Inpal Energie - Cologne
- United Kingdom: Inpal Energy - London



### Sales Management:

238, rue des Frères Voisin  
ZAC Chapotin  
69970 Chaponnay  
Tel. : +33 (0)4.78.69.63.20  
Fax : +33 (0)4.72.71.89.52  
contact : [contact@inpal.com](mailto:contact@inpal.com)



### Production sites in France:

- Creutzwald (France)
- Sens (France)

Ideally located in the centre of Europe, **Inpal Energie's** two production sites can offer short delivery times and an optimised carbon balance for transport.



# References

Inpal Energie's extensive experience makes us an expert partner in pre-insulated networks.

The following companies have chosen to work with **Inpal Energie**:

A.B.P., AIRBUS, AGBAR, AMEC SPIE, AXIMA, BIR, BRANOVERCALIQUA, COGEIS, CEGELEC, CITY OF GENEVA (SIG), CITY OF MUNICH (SWM), CLIMESPACE, CLIMAESPACO, CLIMATELEC, COFELY, COFELY DISTRICT ENERGY, COGENPOWER, C.P.C.U., CRAM, CTRA, DALKIA, DISTRICLIMA, EUROPEAN SPACE AGENCY, EGCS, ENDEL, ETDE, FRENCH MINISTRY OF DEFENCE, GDF SUEZ, HERVE THERMIQUE, IDEX, IMHOFF, NATO, MICHELIN, MISSENARD QUINT B, P.A.M. PERGAZ, PLCO, SADE, SCCU, SCUC, SNEF, SOBEA, SOGEA, TELCHA, TUNZINI, VEOLIA ENVIRONNEMENT...and many others.

With them, we have installed the following networks:

The London 2012 Olympic Games Park (United Kingdom), Zona Franca and Forum 2004 in Barcelona (Spain), Expo 98 in Lisbon (Portugal), CLIMESPACE in Paris, Disneyland Paris, the Colmar, Tours, Cambray, Istres, Creil and St Dizier airbases, Cities of Torino, La Thuile and Borgaro (Italy), the city of Munich (Germany), the city of Mons (Belgium)...



# Quality

**Inpal Energie** is certified ISO 9001.

This quality system means Inpal Energie can guarantee that all administrative, design, production and test procedures are executed in compliance with best industry practices.

All products delivered are manufactured in compliance with the following European Standards:

- EN 253 for pre-insulated pipes.
- EN 448 for fittings.
- EN 488 for valves.
- EN 489 for junctions.
- EN 14419 for the monitoring system.
- EN 13941 for design and calculations.

All our products are subject to a **Technical Evaluation delivered by the CSTB** (Scientific and Technical Centre for the Construction Industry) and Euroheat & Power.

The Technical Evaluation is a document providing technical information on the fitness of purpose of a construction product, material, element or component which is new or innovative.

The Technical Evaluation provides information from both the owner of the technology, and the opinion of a group of independent experts regarding the fitness for purpose of the product concerned.

It therefore aims to provide clear information to various stakeholders in the construction industry thus allowing them to exercise their responsibilities.



Our product Polyuretub 130 is accredited by the CSTB as “**Certifié CSTB Certified**” for our two production sites and is on the GREEN LIST for construction insurance.

”Certifié CSTB Certified” accreditation guarantees the compliance of:

- The main pipe
- The protective casing
- The insulation
- The pre-insulated pipe system
- The jointing system
- Training for personnel on site
- Technical assistance

Our Polyuretub 130 product is **EHP certified**. The “EuroHeat & Power” certification attests to:

- Compliance of audits according to standards EN253, EN 448, EN 14419 and EN 15698-1.
- The compliance and regular undertaking of type tests and in-process tests.



# Environment

**INPAL Energie** sees the preservation of the environment as a vital factor for the company's development. In the wake of the Kyoto agreement, the polyurethane foam we use does not contain any gases which may be harmful to the ozone layer and limits greenhouse gas emissions.

All the components we use in manufacturing strictly conform to the European standards and regulations in force with regard to the protection of the environment. The formulation of our foams allows us to obtain excellent insulation properties and improved durability, which minimise costs and the frequency of renewal.

Polyurethane foam thermal insulation is the most effective insulation technique used to date. **INPAL Energie's** expertise in this technology will contribute to improving the situation for future generations.



All our development, production and storage processes, as well as the transportation and installation of our products are assessed and developed with the constant aim of reducing their impact on the environment. This includes resource protection as well as gas and particle emissions and waste management.

The Quality Department is responsible for applying **ISO 9001, ISO 14001 and OHSAS 18001** standards to all our processes.

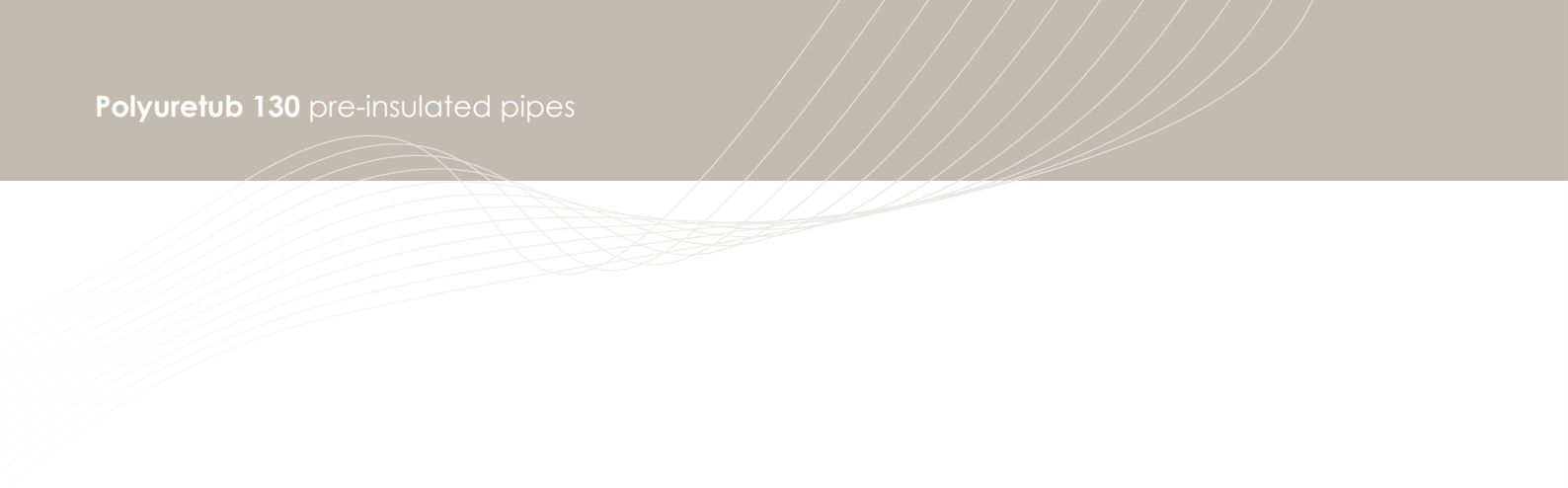



# Technical data

- 14 Insulation range
- 15 Straight pipes
- 16 Bends
- 18 Tee branches
- 24 Anchors
- 25 Bellows
- 26 Reductions
- 27 Valves
- 30 Injected junction kits
- 36 Half-shell junction kits
- 38 District Heating End Cap (DHEC)
- 40 Wall crossing
- 42 Expansion pads
- 44 Monitoring Systems
- 46 Geolocation systems



# Insulation range

The **Polyuretub 130** pre-insulated range produced with black steel pipes is available in various insulation thicknesses: standard, ⊕ and ⊕⊕.

Table of combinations :

Steel pipe			Standard insulation		Insulation ⊕		Insulation ⊕⊕	
ND	Outer Ø	Wall thickness	Casing		Casing		Casing	
			Outer Ø	Wall thickness	Outer Ø	Wall thickness	Outer Ø	Wall thickness
mm	mm	mm	mm	mm	mm	mm	mm	mm
20	26,9	2,0	90	3,0	110	3	125	3,0
25	33,7	2,6	90	3,0	110	3	125	3,0
32	42,4	2,6	110	3,0	125	3	140	3,0
40	48,3	2,6	110	3,0	125	3	140	3,0
50	60,3	2,9	125	3,0	140	3	160	3,0
65	76,1	2,9	140	3,0	160	3	180	3,0
80	88,9	3,2	160	3,0	180	3	200	3,2
100	114,3	3,6	180	3,0	225	3,5*	250	3,6
100	114,3	3,6	200	3,2	225	3,5*	250	3,6
125	139,7	3,6	200	3,2	250	3,6	280	4,4*
125	139,7	3,6	225	3,5*	250	3,6	280	4,4*
150	168,3	4,0	250	3,6	280	4,4*	315	4,5
200	219,1	4,5	315	4,5*	355*	5,1*	400*	5,7*
250	273,1	5,0	355	5,1*	450*	7*	500*	7,8*
250	273,1	5,0	400	5,7*	450*	7*	500*	7,8*
300	323,9	5,6	400	5,7*	500*	7,8*	560*	8,8*
300	323,9	5,6	450	7,0*	500*	7,8*	560*	8,8*
350	355,6	5,6	450	7,0*	560*	8,8*	630*	9,8*
350	355,6	5,6	500	7,8*	560*	8,8*	630*	9,8*
400	406,4	6,3	500	7,8*	630*	9,8*	710*	11,1*
400	406,4	6,3	560	8,8*	630*	9,8*	710*	11,1*
450	457,0	6,3	560	8,8*	630*	9,8*	710*	11,1*
500	508,0	6,3	630	9,8*	710*	11,1*	800*	12,5*
600	610,0	7,1	710	11,1*	800*	12,5*	900*	14,0*
700	711,0	8,0	900	14,0*	On request			
800	813,0	8,8	1000	15,6*	On request			
900	914,0	10,0	1100	On request				
1000	1016,0	11,0	1200	On request				

\* **Inpal Energie** reserves the right to manufacture the minimum thickness required by EN 253 at any time, without prior notice. This applies to all pre-insulated parts included in this catalogue.



# Straight pipes

**Standard:** EN 253

Welded steel pipes according to EN 10217-1, 10217-2, 10217-5\*.

Seamless steel pipes according to EN 10216-2\*

\*Other grades may be proposed upon request.

**Operating temperature:** max. +148 °C

**Operating pressure:** NP 25

Smooth ends for butt welding.

The ends of each part are not insulated over a length of 150 mm.

A monitoring system with detection wires can be supplied upon request.

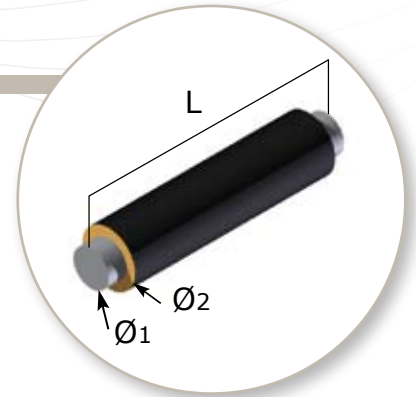

Steel pipe Ø1		Casing Ø2	Pre-insulated pipe		
ND	Outer Ø	Outer Ø	Length L	Approx. weight	Water cont.
mm	mm	mm	m	kg / m	l / m
20	26,9	90	6	2,5	0,4
25	33,7	90	6	2,9	0,7
32	42,4	110	12	4,2	1,1
40	48,3	110	12	4,5	1,5
50	60,3	125	12	6,1	2,3
65	76,1	140	12	7,2	3,9
80	88,9	160	12	9,2	5,3
100	114,3	180	12	12,9	9,0
100	114,3	200	12	13,6	9,0
125	139,7	200	12	15,0	13,8
125	139,7	225	12	16,1	13,8
150	168,3	250	12	20,9	20,2
200	219,1	315	12	31,5	34,6
250	273,1	355	12	41,5	54,2
250	273,1	400	12	45,0	54,2
300	323,9	400	12	54,8	76,7
300	323,9	450	12	59,6	76,7
350	355,6	450	12	62,6	93,0
350	355,6	500	12	67,8	93,0
400	406,4	500	12	78,5	121,6
450	457,0	560	12	91,5	154,8
500	508,0	630	12	106,0	192,4
600	610,0	710	12	137,0	278,3
700	711,0	900	12	196,0	378,7
800	813,0	1000	12	233,0	496,0
900			On request		
1000			On request		

The characteristics of the above pipes correspond to standard use.

**Inpal Energie** may propose other types of products to meet the requirements of individual specifications (thicker insulation or casing).

## Bends 3D standard angle : 90° and 45°

**Standard:** EN 448

**Operating temperature:** max. +148 °C

**Operating pressure:** NP 25

Different angles available upon request.

The ends of each part are not insulated over a length of 150 mm.

A monitoring system with detection wires can be supplied upon request.

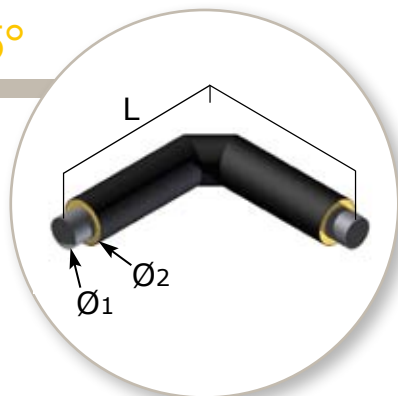

Steel pipe Ø1		Casing Ø2	Pre-insulated bend				
ND	Outer Ø	Outer Ø	Radius	90° branch L	90° approx. weight	45° branch L	45° approx. weight
mm	mm	mm	mm	m	kg / pce	m	kg / pce
20	26,9	90	100	1,0 x 1,0	5	1,0 x 1,0	5
25	33,7	90	140	1,0 x 1,0	6	1,0 x 1,0	6
32	42,4	110	160	1,0 x 1,0	8	1,0 x 1,0	8
40	48,3	110	190	1,0 x 1,0	9	1,0 x 1,0	9
50	60,3	125	250	1,0 x 1,0	11	1,0 x 1,0	11
65	76,1	140	250	1,0 x 1,0	14	1,0 x 1,0	14
80	88,9	160	270	1,0 x 1,0	18	1,0 x 1,0	18
100	114,3	180	285	1,0 x 1,0	23	1,0 x 1,0	23
100	114,3	200	285	1,0 x 1,0	26	1,0 x 1,0	26
125	139,7	200	229	1,0 x 1,0	29	1,0 x 1,0	29
125	139,7	225	229	1,0 x 1,0	31	1,0 x 1,0	31
150	168,3	250	270	1,0 x 1,0	40	1,0 x 1,0	41
200	219,1	315	305	1,0 x 1,0	60	1,0 x 1,0	62
250	273,1	355	381	1,0 x 1,0	78	1,0 x 1,0	82
250	273,1	400	381	1,0 x 1,0	85	1,0 x 1,0	89
300	323,9	400	457	1,0 x 1,0	99	1,0 x 1,0	105
300	323,9	450	457	1,0 x 1,0	110	1,0 x 1,0	117
350	355,6	450	533	1,1 x 1,1	126	1,0 x 1,0	124
350	355,6	500	533	1,1 x 1,1	138	1,0 x 1,0	135
400	406,4	500	610	1,1 x 1,1	157	1,0 x 1,0	156
450	457,0	560	686	1,2 x 1,2	198	1,0 x 1,0	180
500	508,0	630	762	1,3 x 1,3	246	1,0 x 1,0	207
600	610,0	710	914	1,4 x 1,4	342	1,0 x 1,0	272
700	711,0	900	1067	1,6 x 1,6	555	1,0 x 1,0	384
800	813,0	1000	1219	1,7 x 1,7	708	1,0 x 1,0	467
900				On request			
1000				On request			

## Bends 5D standard angle : 90° and 45°

**Standard:** EN 448

**Operating temperature:** max. +148 °C

**Operating pressure:** NP 25

Different angles available upon request.

The ends of each part are not insulated over a length of 150 mm.

A monitoring system with detection wires can be supplied upon request.

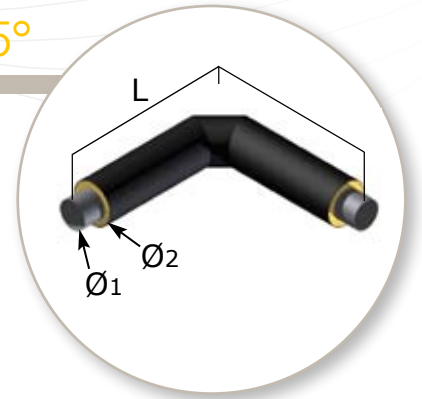

Steel pipe Ø1		Casing Ø2	Pre-insulated bend				
ND	Outer Ø	Outer Ø	Radius	90° branch L	90° approx. weight	45° branch L	45° approx. weight
mm	mm	mm	mm	m	kg / pce	m	kg / pce
20	26,9	90	100	1,0 x 1,0	5	1,0 x 1,0	5
25	33,7	90	140	1,0 x 1,0	6	1,0 x 1,0	6
32	42,4	110	160	1,0 x 1,0	8	1,0 x 1,0	8
40	48,3	110	190	1,0 x 1,0	9	1,0 x 1,0	9
50	60,3	125	250	1,0 x 1,0	11	1,0 x 1,0	11
65	76,1	140	250	1,0 x 1,0	14	1,0 x 1,0	14
80	88,9	160	270	1,0 x 1,0	18	1,0 x 1,0	18
100	114,3	180	285	1,0 x 1,0	23	1,0 x 1,0	23
100	114,3	200	285	1,0 x 1,0	26	1,0 x 1,0	26
125	139,7	200	330	1,0 x 1,0	30	1,0 x 1,0	29
125	139,7	225	330	1,0 x 1,0	31	1,0 x 1,0	31
150	168,3	250	390	1,0 x 1,0	40	1,0 x 1,0	39
200	219,1	315	515	1,0 x 1,0	58	1,0 x 1,0	57
250	273,1	355	650	1,3 x 1,3	99	1,15 x 1,15	98
250	273,1	400	650	1,3 x 1,3	108	1,15 x 1,15	107
300	323,9	400	770	1,5 x 1,5	148	1,35 x 1,35	147
300	323,9	450	770	1,5 x 1,5	163	1,35 x 1,35	162
350	355,6	450	850	1,6 x 1,6	181	1,4 x 1,4	180
350	355,6	500	850	1,6 x 1,6	198	1,4 x 1,4	197
400	406,4	500	970	1,6 x 1,6	226	1,4 x 1,4	224
450	457,0	560	1122	1,45 x 1,45	226	1,0 x 1,0	216
500	508,0	630	1245	1,6 x 1,6	290	1,6 x 1,6	290
600	610,0	710	1525	1,9 x 1,9	443	1,0 x 1,0	398
700	711,0	900	1778	2,1 x 2,1	690	1,1 x 1,1	640
800	813,0	1000	2033	2,4 x 2,4	1579	1,2 x 1,2	807
900				On request			
1000				On request			

# Straight T-branches

Straight T-branches are mainly used for vents and drains.  
Special tees are available with service valve.

**Standard:** EN 448

**Operating temperature:** max. +148 °C

**Operating pressure:** NP 16

The tees are manufactured and all combinations can be supplied.

Special branch lengths can be manufactured.

The ends of each part are not insulated over a length of 150 mm.

A monitoring system with detection wires can be supplied upon request.

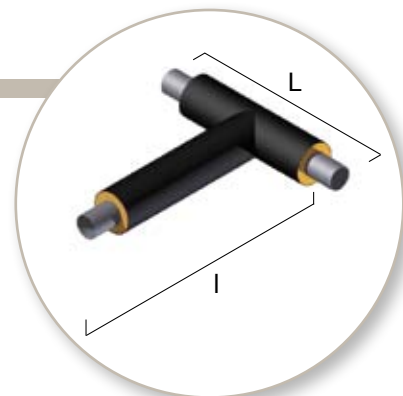

Steel pipe		Casing	Pre-insulated equal tee		
ND	Outer Ø	Outer Ø	Main length L	Branch length I	Approx. weight
mm	mm	mm	m	m	kg / pce
20 x 20	26,9	90	1,0	1,0	5
25 x 25	33,7	90	1,0	1,0	6
32 x 32	42,4	110	1,0	1,0	8
40 x 40	48,3	110	1,0	1,0	8
50 x 50	60,3	125	1,0	1,0	11
65 x 65	76,1	140	1,0	1,0	14
80 x 80	88,9	160	1,0	1,0	18
100 x 100	114,3	180	1,0	1,0	24
100 x 100	114,3	200	1,0	1,0	25
125 x 125	139,7	200	1,0	1,0	30
125 x 125	139,7	225	1,0	1,0	31
150 x 150	168,3	250	1,0	1,0	40
200 x 200	219,1	315	1,1	1,0	64
250 x 250	273,1	355	1,1	1,0	85
250 x 250	273,1	400	1,1	1,0	91
300 x 300	323,9	400	1,1	1,0	111
300 x 300	323,9	450	1,2	1,0	126
350 x 350	355,6	450	1,2	1,0	134
350 x 350	355,6	500	1,2	1,0	143
400 x 400	406,4	500	1,2	1,0	169
450 x 450	457,0	560	1,3	1,0	203
500 x 500	508,0	630	1,4	1,0	243
600 x 600	610,0	710	1,5	1,0	332
700 x 700	711,0	900	1,6	1,0	480
800 x 800	813,0	1000	1,7	1,0	609
900 x 900			On request		
1000 x 1000			On request		

# Straight T-branches with reduced branch

Branch	Main pipe												
	20	25	32	40	50	65	80	100	100	125	125	150	200
	90	90	110	110	125	140	160	180	200	200	225	250	315
	L x l	L x l	L x l	L x l	L x l	L x l	L x l	L x l	L x l	L x l	L x l	L x l	L x l
20	90	1,0 x 1,0	1,0 x 1,0	1,0 x 1,0	1,0 x 1,0	1,0 x 1,0	1,0 x 1,0	1,0 x 1,0	1,0 x 1,0	1,0 x 1,0	1,0 x 1,0	1,0 x 1,0	1,0 x 1,0
25	90			1,0 x 1,0	1,0 x 1,0	1,0 x 1,0	1,0 x 1,0	1,0 x 1,0	1,0 x 1,0	1,0 x 1,0	1,0 x 1,0	1,0 x 1,0	1,0 x 1,0
32	110				1,0 x 1,0	1,0 x 1,0	1,0 x 1,0	1,0 x 1,0	1,0 x 1,0	1,0 x 1,0	1,0 x 1,0	1,0 x 1,0	1,0 x 1,0
40	110					1,0 x 1,0	1,0 x 1,0	1,0 x 1,0	1,0 x 1,0	1,0 x 1,0	1,0 x 1,0	1,0 x 1,0	1,0 x 1,0
50	125						1,0 x 1,0	1,0 x 1,0	1,0 x 1,0	1,0 x 1,0	1,0 x 1,0	1,0 x 1,0	1,0 x 1,0
65	140							1,0 x 1,0	1,0 x 1,0	1,0 x 1,0	1,0 x 1,0	1,0 x 1,0	1,0 x 1,0
80	160								1,0 x 1,0	1,0 x 1,0	1,0 x 1,0	1,0 x 1,0	1,0 x 1,0
100	180										1,0 x 1,0	1,0 x 1,0	1,0 x 1,0
100	200											1,0 x 1,0	1,0 x 1,0
125	200												1,0 x 1,0
125	225												
150	250												

Branch												
	250	250	300	300	350	350	400	450	500	600	700	800
	355	400	400	450	450	500	500	560	630	710	900	1000
	L x l	L x l	L x l	L x l	L x l	L x l	L x l	L x l	L x l	L x l	L x l	L x l
20	90	1,0 x 1,0	1,0 x 1,0	1,0 x 1,0	1,0 x 1,0	1,0 x 1,0	1,0 x 1,0	1,0 x 1,0	1,0 x 1,0	1,0 x 1,0	1,0 x 1,0	1,0 x 1,0
25	90	1,0 x 1,0	1,0 x 1,0	1,0 x 1,0	1,0 x 1,0	1,0 x 1,0	1,0 x 1,0	1,0 x 1,0	1,0 x 1,0	1,0 x 1,0	1,0 x 1,0	1,0 x 1,0
32	110	1,0 x 1,0	1,0 x 1,0	1,0 x 1,0	1,0 x 1,0	1,0 x 1,0	1,0 x 1,0	1,0 x 1,0	1,0 x 1,0	1,0 x 1,0	1,0 x 1,0	1,0 x 1,0
40	110	1,0 x 1,0	1,0 x 1,0	1,0 x 1,0	1,0 x 1,0	1,0 x 1,0	1,0 x 1,0	1,0 x 1,0	1,0 x 1,0	1,0 x 1,0	1,0 x 1,0	1,0 x 1,0
50	125	1,0 x 1,0	1,0 x 1,0	1,0 x 1,0	1,0 x 1,0	1,0 x 1,0	1,0 x 1,0	1,0 x 1,0	1,0 x 1,0	1,0 x 1,0	1,0 x 1,0	1,0 x 1,0
65	140	1,0 x 1,0	1,0 x 1,0	1,0 x 1,0	1,0 x 1,0	1,0 x 1,0	1,0 x 1,0	1,0 x 1,0	1,0 x 1,0	1,0 x 1,0	1,0 x 1,0	1,0 x 1,0
80	160	1,0 x 1,0	1,0 x 1,0	1,0 x 1,0	1,0 x 1,0	1,0 x 1,0	1,0 x 1,0	1,0 x 1,0	1,0 x 1,0	1,0 x 1,0	1,0 x 1,0	1,0 x 1,0
100	180	1,0 x 1,0	1,0 x 1,0	1,0 x 1,0	1,0 x 1,0	1,0 x 1,0	1,0 x 1,0	1,0 x 1,0	1,0 x 1,0	1,0 x 1,0	1,0 x 1,0	1,0 x 1,0
100	200	1,0 x 1,0	1,0 x 1,0	1,0 x 1,0	1,0 x 1,0	1,0 x 1,0	1,0 x 1,0	1,0 x 1,0	1,0 x 1,0	1,0 x 1,0	1,0 x 1,0	1,0 x 1,0
125	200	1,0 x 1,0	1,0 x 1,0	1,0 x 1,0	1,0 x 1,0	1,0 x 1,0	1,0 x 1,0	1,0 x 1,0	1,0 x 1,0	1,0 x 1,0	1,0 x 1,0	1,0 x 1,0
125	225	1,0 x 1,0	1,0 x 1,0	1,0 x 1,0	1,0 x 1,0	1,0 x 1,0	1,0 x 1,0	1,0 x 1,0	1,0 x 1,0	1,0 x 1,0	1,0 x 1,0	1,0 x 1,0
150	250	1,0 x 1,0	1,0 x 1,0	1,0 x 1,0	1,0 x 1,0	1,0 x 1,0	1,0 x 1,0	1,0 x 1,0	1,0 x 1,0	1,0 x 1,0	1,0 x 1,0	1,0 x 1,0
200	315	1,1 x 1,0	1,1 x 1,0	1,1 x 1,0	1,1 x 1,0	1,1 x 1,0	1,1 x 1,0	1,1 x 1,0	1,1 x 1,0	1,1 x 1,0	1,1 x 1,0	1,1 x 1,0
250	355			1,1 x 1,0	1,1 x 1,0	1,1 x 1,0	1,1 x 1,0	1,1 x 1,0	1,1 x 1,0	1,1 x 1,0	1,1 x 1,0	1,1 x 1,0
250	400				1,1 x 1,0	1,1 x 1,0	1,1 x 1,0	1,1 x 1,0	1,1 x 1,0	1,1 x 1,0	1,1 x 1,0	1,1 x 1,0
300	400					1,1 x 1,0	1,1 x 1,0	1,1 x 1,0	1,1 x 1,0	1,1 x 1,0	1,1 x 1,0	1,1 x 1,0
300	450						1,2 x 1,0	1,2 x 1,0	1,2 x 1,0	1,2 x 1,0	1,2 x 1,0	1,2 x 1,0
350	450							1,2 x 1,0	1,2 x 1,0	1,2 x 1,0	1,2 x 1,0	1,2 x 1,0
350	500								1,2 x 1,0	1,2 x 1,0	1,2 x 1,0	1,2 x 1,0
400	500									1,2 x 1,0	1,2 x 1,0	1,2 x 1,0
450	560										1,3 x 1,0	1,3 x 1,0
500	630											1,4 x 1,0
600	710											

# 45° jump T-branches

**Standard:** EN 448

**Operating temperature:** max. +148 °C

**Operating pressure:** NP 16

The tees are manufactured and all combinations can be supplied.

Special branch lengths can be manufactured.

The ends of each part are not insulated over a length of 150 mm.

A monitoring system with detection wires can be supplied upon request.



Steel pipe		Casing	Pre-insulated equal tee			
ND	Outer Ø	Outer Ø	Main length L	Branch length I	Overall H	Approx. weight
mm	mm	mm	m	m	m	kg / pce
20 x 20	26,9	90	1,0	1,0	0,23	5
25 x 25	33,7	90	1,0	1,0	0,23	6
32 x 32	42,4	110	1,0	1,0	0,27	8
40 x 40	48,3	110	1,0	1,0	0,27	9
50 x 50	60,3	125	1,0	1,0	0,30	12
65 x 65	76,1	140	1,0	1,0	0,33	14
80 x 80	88,9	160	1,0	1,0	0,37	18
100 x 100	114,3	180	1,0	1,0	0,41	26
100 x 100	114,3	200	1,0	1,0	0,45	27
125 x 125	139,7	200	1,0	1,0	0,45	31
125 x 125	139,7	225	1,0	1,0	0,50	33
150 x 150	168,3	250	1,0	1,0	0,55	43
200 x 200	219,1	315	1,1	1,0	0,68	69
250 x 250	273,1	355	1,1	1,0	0,76	92
250 x 250	273,1	400	1,1	1,0	0,85	100
300 x 300	323,9	400	1,1	1,0	0,85	122
300 x 300	323,9	450	1,2	1,0	0,95	140
350 x 350	355,6	450	1,2	1,0	0,95	154
350 x 350	355,6	500	1,2	1,0	1,05	168
400 x 400	406,4	500	1,2	1,1	1,05	178
450 x 450	457,0	560	1,3	1,1	1,17	246
500 x 500	508,0	630	1,4	1,3	1,31	307
600 x 600	610,0	710	1,5	1,5	1,47	447
700 x 700	711,0	900	1,6	1,7	1,85	701
800 x 800	813,0	1000	1,7	1,9	2,05	934
900 x 900						On request
1000 x 1000						On request



# 45° jump T-branches with reduced branch

Branch		Main pipe												
		20	25	32	40	50	65	80	100	100	125	125	150	200
		90	90	110	110	125	140	160	180	200	200	225	250	315
		L x l	L x l	L x l	L x l	L x l	L x l	L x l	L x l	L x l	L x l	L x l	L x l	
20	90	1,0 x 1,0	1,0 x	1,0 x 1,0	1,0 x 1,0	1,0 x 1,0	1,0 x 1,0	1,0 x 1,0	1,0 x 1,0	1,0 x 1,0	1,0 x 1,0	1,0 x 1,0	1,0 x 1,0	
25	90			1,0 x 1,0	1,0 x 1,0	1,0 x 1,0	1,0 x 1,0	1,0 x 1,0	1,0 x 1,0	1,0 x 1,0	1,0 x 1,0	1,0 x 1,0	1,0 x 1,0	
32	110				1,0 x 1,0	1,0 x 1,0	1,0 x 1,0	1,0 x 1,0	1,0 x 1,0	1,0 x 1,0	1,0 x 1,0	1,0 x 1,0	1,0 x 1,0	
40	110					1,0 x 1,0	1,0 x 1,0	1,0 x 1,0	1,0 x 1,0	1,0 x 1,0	1,0 x 1,0	1,0 x 1,0	1,0 x 1,0	
50	125						1,0 x 1,0	1,0 x 1,0	1,0 x 1,0	1,0 x 1,0	1,0 x 1,0	1,0 x 1,0	1,0 x 1,0	
65	140							1,0 x 1,0	1,0 x 1,0	1,0 x 1,0	1,0 x 1,0	1,0 x 1,0	1,0 x 1,0	
80	160								1,0 x 1,0	1,0 x 1,0	1,0 x 1,0	1,0 x 1,0	1,0 x 1,0	
100	180									1,0 x 1,0	1,0 x 1,0	1,0 x 1,0	1,0 x 1,0	
100	200										1,0 x 1,0	1,0 x 1,0	1,0 x 1,0	
125	200											1,0 x 1,0	1,0 x 1,0	
125	225												1,0 x 1,0	

Branch		250	250	300	300	350	350	400	450	500	600	700	800
		355	400	400	450	450	500	500	560	630	710	900	1000
		L x l	L x l	L x l	L x l	L x l	L x l	L x l	L x l	L x l	L x l	L x l	L x l
20	90	1,0 x 1,0	1,0 x 1,0	1,0 x 1,0	1,0 x 1,0	1,0 x 1,0	1,0 x 1,0	1,0 x 1,0	1,0 x 1,0	1,0 x 1,0	1,0 x 1,0	1,0 x 1,0	1,0 x 1,0
25	90	1,0 x 1,0	1,0 x 1,0	1,0 x 1,0	1,0 x 1,0	1,0 x 1,0	1,0 x 1,0	1,0 x 1,0	1,0 x 1,0	1,0 x 1,0	1,0 x 1,0	1,0 x 1,0	1,0 x 1,0
32	110	1,0 x 1,0	1,0 x 1,0	1,0 x 1,0	1,0 x 1,0	1,0 x 1,0	1,0 x 1,0	1,0 x 1,0	1,0 x 1,0	1,0 x 1,0	1,0 x 1,0	1,0 x 1,0	1,0 x 1,0
40	110	1,0 x 1,0	1,0 x 1,0	1,0 x 1,0	1,0 x 1,0	1,0 x 1,0	1,0 x 1,0	1,0 x 1,0	1,0 x 1,0	1,0 x 1,0	1,0 x 1,0	1,0 x 1,0	1,0 x 1,0
50	125	1,0 x 1,0	1,0 x 1,0	1,0 x 1,0	1,0 x 1,0	1,0 x 1,0	1,0 x 1,0	1,0 x 1,0	1,0 x 1,0	1,0 x 1,0	1,0 x 1,0	1,0 x 1,0	1,0 x 1,0
65	140	1,0 x 1,0	1,0 x 1,0	1,0 x 1,0	1,0 x 1,0	1,0 x 1,0	1,0 x 1,0	1,0 x 1,0	1,0 x 1,0	1,0 x 1,0	1,0 x 1,0	1,0 x 1,0	1,0 x 1,0
80	160	1,0 x 1,0	1,0 x 1,0	1,0 x 1,0	1,0 x 1,0	1,0 x 1,0	1,0 x 1,0	1,0 x 1,0	1,0 x 1,0	1,0 x 1,0	1,0 x 1,0	1,0 x 1,0	1,0 x 1,0
100	180	1,0 x 1,0	1,0 x 1,0	1,0 x 1,0	1,0 x 1,0	1,0 x 1,0	1,0 x 1,0	1,0 x 1,0	1,0 x 1,0	1,0 x 1,0	1,0 x 1,0	1,0 x 1,0	1,0 x 1,0
100	200	1,0 x 1,0	1,0 x 1,0	1,0 x 1,0	1,0 x 1,0	1,0 x 1,0	1,0 x 1,0	1,0 x 1,0	1,0 x 1,0	1,0 x 1,0	1,0 x 1,0	1,0 x 1,0	1,0 x 1,0
125	200	1,0 x 1,0	1,0 x 1,0	1,0 x 1,0	1,0 x 1,0	1,0 x 1,0	1,0 x 1,0	1,0 x 1,0	1,0 x 1,0	1,0 x 1,0	1,0 x 1,0	1,0 x 1,0	1,0 x 1,0
125	225	1,0 x 1,0	1,0 x 1,0	1,0 x 1,0	1,0 x 1,0	1,0 x 1,0	1,0 x 1,0	1,0 x 1,0	1,0 x 1,0	1,0 x 1,0	1,0 x 1,0	1,0 x 1,0	1,0 x 1,0
150	250	1,0 x 1,0	1,0 x 1,0	1,0 x 1,0	1,0 x 1,0	1,0 x 1,0	1,0 x 1,0	1,0 x 1,0	1,0 x 1,0	1,0 x 1,0	1,0 x 1,0	1,0 x 1,0	1,0 x 1,0
200	315	1,1 x 1,0	1,1 x 1,0	1,1 x 1,0	1,1 x 1,0	1,1 x 1,0	1,1 x 1,0	1,1 x 1,0	1,1 x 1,0	1,1 x 1,0	1,1 x 1,0	1,1 x 1,1	1,1 x 1,2
250	355			1,1 x 1,0	1,1 x 1,0	1,1 x 1,0	1,1 x 1,0	1,1 x 1,0	1,1 x 1,0	1,1 x 1,1	1,1 x 1,1	1,1 x 1,2	1,1 x 1,2
250	400			1,1 x 1,0	1,1 x 1,0	1,1 x 1,0	1,1 x 1,0	1,1 x 1,0	1,1 x 1,0	1,1 x 1,1	1,1 x 1,1	1,1 x 1,2	1,1 x 1,2
300	400					1,1 x 1,0	1,1 x 1,1	1,1 x 1,1	1,1 x 1,1	1,1 x 1,1	1,1 x 1,2	1,1 x 1,3	1,1 x 1,3
300	450						1,2 x 1,0	1,1 x 1,1	1,1 x 1,1	1,1 x 1,1	1,1 x 1,2	1,1 x 1,3	1,1 x 1,3
350	450							1,2 x 1,1	1,2 x 1,1	1,2 x 1,2	1,2 x 1,2	1,2 x 1,3	1,2 x 1,3
350	500								1,2 x 1,1	1,2 x 1,2	1,2 x 1,2	1,2 x 1,3	1,2 x 1,4
400	500									1,2 x 1,2	1,2 x 1,2	1,2 x 1,3	1,2 x 1,4
450	560										1,3 x 1,3	1,3 x 1,3	1,3 x 1,4
500	630											1,4 x 1,4	1,4 x 1,5
600	710												1,5 x 1,6
700	900												1,6 x 1,8

# Parallel T-branches

**Standard:** EN 448

**Operating temperature:** max. +148 °C

**Operating pressure:** NP 16

The tees are manufactured and all combinations can be supplied.

Special branch lengths can be manufactured.

The ends of each part are not insulated over a length of 150 mm.

A monitoring system with detection wires can be supplied upon request.

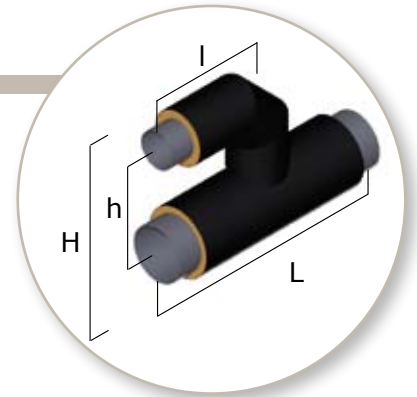

Steel pipe		Casing	Pre-insulated equal tee			
ND	Outer Ø	Outer Ø	Main length L	Branch length l	Overall H	Approx. weight
mm	mm	mm	m	m	m	kg / pce
20 x 20	26,9	90	1,0	0,5	0,33	4
25 x 25	33,7	90	1,0	0,5	0,33	5
32 x 32	42,4	110	1,0	0,5	0,37	7
40 x 40	48,3	110	1,0	0,5	0,37	7
50 x 50	60,3	125	1,0	0,5	0,40	10
65 x 65	76,1	140	1,0	0,5	0,43	14
80 x 80	88,9	160	1,0	0,5	0,47	17
100 x 100	114,3	180	1,0	0,5	0,51	23
100 x 100	114,3	200	1,0	0,5	0,55	24
125 x 125	139,7	200	1,1	0,55	0,56	34
125 x 125	139,7	225	1,1	0,55	0,61	36
150 x 150	168,3	250	1,1	0,55	0,67	52
200 x 200	219,1	315	1,2	0,6	0,84	90
250 x 250	273,1	355	1,4	0,7	1,13	132
250 x 250	273,1	400	1,4	0,7	1,22	132
300 x 300	323,9	400	1,6	0,8	1,26	198
300 x 300	323,9	450	1,6	0,8	1,36	211
350 x 350	355,6	450	1,7	0,85	1,40	245
350 x 350	355,6	500	1,7	0,85	1,50	262
400 x 400	406,4	500	1,9	0,95	1,53	359
450 x 450	457,0	560	2	1,0	1,68	434
500 x 500	508,0	630	2,2	1,10	1,85	552
600 x 600	610,0	710	2,5	1,25	2,08	894
700 x 700	711,0	900	2,8	1,40	2,48	1401
800 x 800	813,0	1000	3,1	1,55	2,73	1879
900 x 900			On request			
1000 x 1000			On request			

# Parallel T-branches with reduced branch

Branch		Main pipe										
		25	32	40	50	65	80	100	100	125	125	150
		90	110	110	125	140	160	180	200	200	225	250
		L x h	L x h	L x h	L x h	L x h	L x h	L x h	L x h	L x h	L x h	L x h
20	90	1,0 x 0,24	1,0 x 0,25	1,0 x 0,25	1,0 x 0,26	1,0 x 0,27	1,0 x 0,28	1,0 x 0,29	1,0 x 0,30	1,0 x 0,30	1,0 x 0,31	1,0 x 0,32
25	90		1,0 x 0,25	1,0 x 0,25	1,0 x 0,26	1,0 x 0,27	1,0 x 0,28	1,0 x 0,29	1,0 x 0,30	1,0 x 0,30	1,0 x 0,31	1,0 x 0,32
32	110			1,0 x 0,26	1,0 x 0,27	1,0 x 0,28	1,0 x 0,29	1,0 x 0,30	1,0 x 0,31	1,0 x 0,31	1,0 x 0,32	1,0 x 0,33
40	110				1,0 x 0,27	1,0 x 0,28	1,0 x 0,29	1,0 x 0,30	1,0 x 0,31	1,0 x 0,31	1,0 x 0,32	1,0 x 0,33
50	125					1,0 x 0,28	1,0 x 0,29	1,0 x 0,30	1,0 x 0,31	1,0 x 0,31	1,0 x 0,33	1,0 x 0,34
65	140						1,0 x 0,30	1,0 x 0,31	1,0 x 0,32	1,0 x 0,32	1,0 x 0,33	1,0 x 0,35
80	160							1,0 x 0,32	1,0 x 0,33	1,0 x 0,33	1,0 x 0,34	1,0 x 0,36
100	180									1,0 x 0,34	1,0 x 0,35	1,0 x 0,37
100	200									1,0 x 0,35	1,0 x 0,36	1,0 x 0,38
125	200											1,1 x 0,39
125	225											1,1 x 0,40

Branch		200	250	250	300	300	350	350	400	450	500	600	700	800
		315	355	400	400	450	450	500	500	560	630	710	900	1000
		L x h	L x h	L x h	L x h	L x h	L x h	L x h	L x h	L x h	L x h	L x h	L x h	L x h
20	90	1,0 x 0,35	1,0 x 0,37	1,0 x 0,4	1,0 x 0,40	1,0 x 0,42	1,0 x 0,42	1,0 x 0,45	1,0 x 0,45	1,0 x 0,48	1,0 x 0,51	1,0 x 0,55	1,0 x 0,65	1,0 x 0,70
25	90	1,0 x 0,35	1,0 x 0,37	1,0 x 0,4	1,0 x 0,40	1,0 x 0,42	1,0 x 0,42	1,0 x 0,45	1,0 x 0,45	1,0 x 0,48	1,0 x 0,51	1,0 x 0,55	1,0 x 0,65	1,0 x 0,70
32	110	1,0 x 0,36	1,0 x 0,38	1,0 x 0,41	1,0 x 0,41	1,0 x 0,43	1,0 x 0,43	1,0 x 0,46	1,0 x 0,46	1,0 x 0,49	1,0 x 0,52	1,0 x 0,56	1,0 x 0,66	1,0 x 0,71
40	110	1,0 x 0,36	1,0 x 0,38	1,0 x 0,41	1,0 x 0,41	1,0 x 0,43	1,0 x 0,43	1,0 x 0,46	1,0 x 0,46	1,0 x 0,49	1,0 x 0,52	1,0 x 0,56	1,0 x 0,66	1,0 x 0,71
50	125	1,0 x 0,37	1,0 x 0,39	1,0 x 0,41	1,0 x 0,41	1,0 x 0,44	1,0 x 0,44	1,0 x 0,46	1,0 x 0,46	1,0 x 0,49	1,0 x 0,53	1,0 x 0,57	1,0 x 0,66	1,0 x 0,71
65	140	1,0 x 0,38	1,0 x 0,40	1,0 x 0,42	1,0 x 0,42	1,0 x 0,45	1,0 x 0,45	1,0 x 0,47	1,0 x 0,47	1,0 x 0,50	1,0 x 0,54	1,0 x 0,58	1,0 x 0,67	1,0 x 0,72
80	160	1,0 x 0,39	1,0 x 0,41	1,0 x 0,43	1,0 x 0,43	1,0 x 0,46	1,0 x 0,46	1,0 x 0,48	1,0 x 0,48	1,0 x 0,51	1,0 x 0,55	1,0 x 0,59	1,0 x 0,68	1,0 x 0,73
100	180	1,0 x 0,40	1,0 x 0,42	1,0 x 0,44	1,0 x 0,44	1,0 x 0,47	1,0 x 0,47	1,0 x 0,49	1,0 x 0,49	1,0 x 0,52	1,0 x 0,56	1,0 x 0,60	1,0 x 0,69	1,0 x 0,74
100	200	1,0 x 0,41	1,0 x 0,43	1,0 x 0,45	1,0 x 0,45	1,0 x 0,48	1,0 x 0,48	1,0 x 0,50	1,0 x 0,50	1,0 x 0,53	1,0 x 0,57	1,0 x 0,61	1,0 x 0,70	1,0 x 0,75
125	200	1,1 x 0,42	1,1 x 0,44	1,1 x 0,46	1,1 x 0,46	1,1 x 0,49	1,1 x 0,49	1,1 x 0,51	1,1 x 0,51	1,1 x 0,54	1,1 x 0,58	1,1 x 0,62	1,1 x 0,71	1,1 x 0,76
125	225	1,1 x 0,43	1,1 x 0,45	1,1 x 0,47	1,1 x 0,47	1,1 x 0,50	1,1 x 0,50	1,1 x 0,52	1,1 x 0,52	1,1 x 0,55	1,1 x 0,59	1,1 x 0,63	1,1 x 0,72	1,1 x 0,77
150	250	1,2 x 0,45	1,1 x 0,47	1,1 x 0,50	1,1 x 0,50	1,1 x 0,52	1,1 x 0,52	1,1 x 0,55	1,1 x 0,55	1,1 x 0,58	1,1 x 0,61	1,1 x 0,65	1,1 x 0,75	1,1 x 0,80
200	315		1,3 x 0,55	1,3 x 0,57	1,3 x 0,57	1,3 x 0,59	1,3 x 0,59	1,3 x 0,62	1,3 x 0,62	1,3 x 0,65	1,3 x 0,68	1,3 x 0,72	1,3 x 0,82	1,3 x 0,87
250	355				1,4 x 0,80	1,4 x 0,83	1,4 x 0,83	1,4 x 0,85	1,4 x 0,85	1,4 x 0,88	1,4 x 0,92	1,4 x 0,96	1,4 x 1,05	1,4 x 1,10
250	400				1,4 x 0,83	1,4 x 0,85	1,4 x 0,85	1,4 x 0,88	1,4 x 0,88	1,4 x 0,91	1,4 x 0,94	1,4 x 0,98	1,4 x 1,08	1,4 x 1,13
300	400					1,6 x 0,89	1,6 x 0,91	1,6 x 0,91	1,6 x 0,94	1,6 x 0,98	1,6 x 1,02	1,6 x 1,11	1,6 x 1,16	
300	450					1,6 x 0,91	1,6 x 0,94	1,6 x 0,94	1,6 x 0,97	1,6 x 1,00	1,6 x 1,04	1,6 x 1,14	1,6 x 1,19	
350	450							1,7 x 0,98	1,7 x 1,01	1,7 x 1,05	1,7 x 1,09	1,7 x 1,18	1,7 x 1,23	
350	500							1,7 x 1,01	1,7 x 1,04	1,7 x 1,07	1,7 x 1,11	1,7 x 1,21	1,7 x 1,26	
400	500							1,9 x 1,07	1,9 x 1,10	1,9 x 1,14	1,9 x 1,24	1,9 x 1,29		
450	560									2,0 x 1,16	2,0 x 1,20	2,0 x 1,29	2,0 x 1,34	
500	630										2,2 x 1,26	2,2 x 1,36	2,2 x 1,41	
600	710											2,5 x 1,47	2,5 x 1,52	
700	900													2,8 x 1,63

# Anchors

Anchors are used to block the network expansion movements at specific points and thereby control the expansion forces.

**Standard:** EN 448

**Operating temperature:** max. +148 °C

**Operating pressure:** NP 25

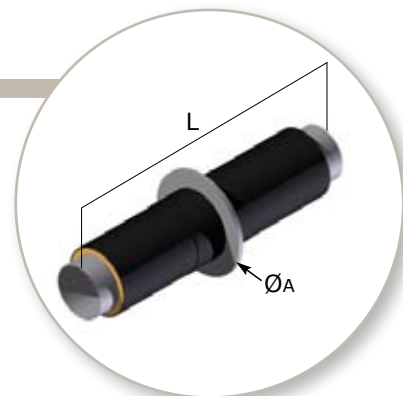

Anchors are supplied prefabricated, ready for installation in concrete foundations.

The ends of each part are not insulated over a length of 150 mm.

A monitoring system with detection wires can be supplied upon request.

Steel pipe		Casing	Pre-insulated anchor			
ND	Outer Ø	Outer Ø	Plate Diam. A	Plate thickness	Length L	Approx. weight
mm	mm	mm	mm	mm	m	kg / pce
20	26,9	90	200	12	2	10
25	33,7	90	200	12	2	11
32	42,4	110	220	14	2	15
40	48,3	110	220	14	2	15
50	60,3	125	235	15	2	19
65	76,1	140	250	18	2	24
80	88,9	160	270	20	2	30
100	114,3	180	290	20	2	38
100	114,3	200	310	20	2	41
125	139,7	200	310	20	2	44
125	139,7	225	335	25	2	51
150	168,3	250	450	25	2	73
200	219,1	315	450	25	2	92
250	273,1	355	560	25	2	126
250	273,1	400	630	35	2	166
300	323,9	400	630	35	2	177
300	323,9	450	680	35	2	201
350	355,6	450	680	35	2	203
350	355,6	500	750	35	2	235
400	406,4	500	750	35	2	250
450	457,0	560	810	40	2	298
500	508,0	630	880	40	2	343
600	610,0	710	960	40	2	415
700	711,0	900	1150	50	2	639
800	813,0	1000	1250	50	2	749
900						On request
1000						On request

# Bellows

Pre-insulated bellows are used to absorb the thermal expansions of the steel pipe within permissible limits.

**Standard:** EN 448

**Operating temperature:** max. +148 °C

**Operating pressure:** NP 16

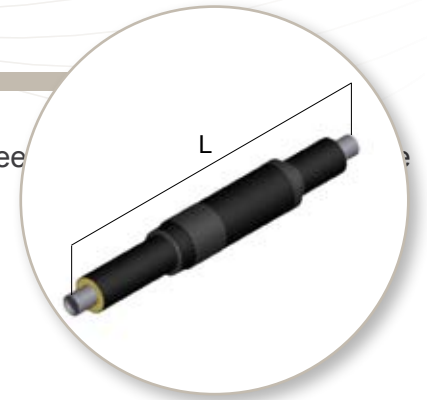

Compensators are supplied prefabricated, ready for installation. The ends of each part are not insulated over a length of 150 mm. A monitoring system with detection wires can be supplied upon request.

Steel pipe		Casing	Pre-insulated bellows		
ND	Outer Ø	Outer Ø	Axial movement	Length L	Approx. weight
mm	mm	mm	mm	m	Kg / pce
40	48,3	110	100	2	15
50	60,3	125	100	2	19
65	76,1	140	100	2	23
80	88,9	160	100/150	2	28
100	114,3	180	125/155	2	41
100	114,3	200	125/155	2	41
125	139,7	200	125/160	2	49
125	139,7	225	125/160	2	50
150	168,3	250	125/165	2	66
200	219,1	315	125/170	2	97
250	273,1	355	125/170	2	138
250	273,1	400	125/170	2	140
300	323,9	400	125/190	2	179
300	323,9	450	125/190	2	183
350	355,6	450	125/190	2	214
350	355,6	500	125/190	2	218
400	406,4	500	125/200	2	253
450	457,0	560	125/200	2	287
500	508,0	630	200	2	324
600	610,0	710		On request	
700	711,0	900		On request	
800	813,0	1000		On request	
900			On request		
1000			On request		

\* Expansion : short axial movement, long axial movement on request.

# Reductions

**Standard:** EN 448

**Operating temperature:** max. +148 °C

**Operating pressure:** NP 25

The reductions are prefabricated and can be reduced by 1 to 3 diameters in compliance with EN10253-2 standard.

The ends of each part are not insulated over a length of 150 mm.

A monitoring system with detection wires can be supplied upon request.

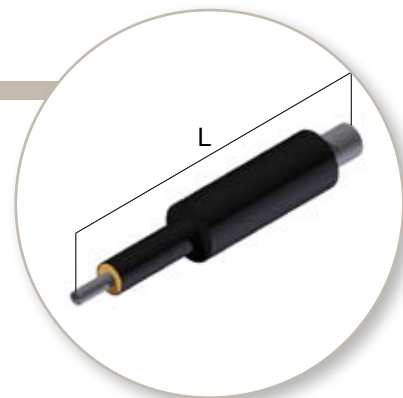

**Length:** = 1.00 m for diameter ≤ 450  
= 1.50 m for diameter ≥ 450

Main pipe			32	40	50	65	80	100	100	125	125	150
			42,4	48,3	60,3	76,1	88,9	114,3	114,3	139,7	139,7	168,3
Reduction			110	110	125	140	160	180	200	200	225	250
20	26,9	90	x	x	x							
25	33,7	90	x	x	x	x						
32	42,4	110		x	x	x	x					
40	48,3	110			x	x	x	x	x			
50	60,3	125				x	x	x	x	x	x	
65	76,1	140					x	x	x	x	x	x
80	88,9	160						x	x	x	x	x
100	114,3	200								x	x	x
125	139,7	225										x

Main pipe			200	250	250	300	300	350	350	400	450	500	600	700	800
			219,1	273,1	273,1	323,9	323,9	355,6	355,6	406,4	457,0	508,0	610,0	711,0	813,0
Reduction			315	355	400	400	450	450	500	500	560	630	710	900	1000
80	88,9	160	x												
100	114,3	200	x	x	x										
125	139,7	225	x	x	x	x	x								
150	168,3	250	x	x	x	x	x	x	x						
200	219,1	315		x	x	x	x	x	x	x					
250	273,1	355				x	x	x	x	x	x				
300	323,9	400					x	x	x	x	x				
300	323,9	450						x	x	x	x				
350	355,6	450							x	x	x				
350	355,6	500							x	x	x				
400	406,4	500								x	x	x			
450	457,0	560									x	x	x		
500	508,0	630										x	x	x	
600	610,0	710											x	x	
700	711,0	900													x



## Ball valves

Pre-insulated valves can be installed at all points on the network. They are mainly used to isolate parts of networks.

Pre-insulated valves are buried directly in the ground when installing pipes. We recommend installing these valves in an area free from any lateral expansion movement.

In district heating networks there are often high axial stresses due to temperature variations. Consequently, it is very important to protect the pre-insulated valves against these so that they can be opened or closed at all times.

The solution is to use a fully-welded valve body which keeps the axial forces away from the valve mechanism so that the forces do not affect its vital parts. A spring system keeps the seats pressed against the ball with a controlled force, independently of the axial forces.

Valves must comply with EN488.

### Example of standard valve characteristics:

The valve body is made from S235JR steel in compliance with EN 10 025 (Idem ST 37). The valve control mechanism and the ball are made from stainless steel. The seats are made from PTFE reinforced carbon. They offer optimum tightness, controlled pressure against the ball and controlled torsion torque. Graphite/PTFE seals are used. Valves with specific stem heights are available upon request.



# Standard ball valves

**Standard:** EN 488

**Operating temperature:** max. +148 °C

**Operating pressure:** NP 25

The ends of each part are not insulated over a length of 150 mm.  
A monitoring system with detection wires can be supplied upon request.

**Standard valves can be supplied with geared actuators.**  
**Inpal Energie recommends the use of geared actuators from ND 125.**

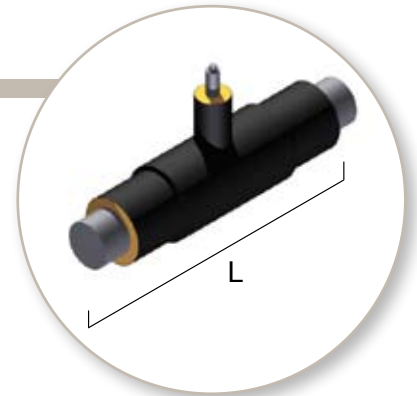

Steel pipe		Casing	Pre-insulated valve	
ND	Outer Ø	Outer Ø	Length	Approx. weight
mm	mm	mm	m	kg / pce
20	26,9	90	1,5	3,8
25	33,7	90	1,5	3,9
32	42,4	110	1,5	4,5
40	48,3	110	1,5	5,4
50	60,3	125	1,5	6,38
65	76,1	140	1,5	9,44
80	88,9	160	1,5	11,27
100	114,3	180	1,5	16,09
100	114,3	200	1,5	16,76
125	139,7	200	1,5	31,60
125	139,7	225	1,5	32,57
150	168,3	250	1,5	43,50
200	219,1	315	1,5	82,67
250	273,1	355	1,5	157,60
300	323,9	400	1,8	247,0
300	323,9	450	1,8	253,4
350	355,6	450	2,2	293,5
350	355,6	500	2,2	303,9
400	406,4	500	2,2	547
450	457,0	560	2,2	900
500	508,0	630	2,2	804
600	610,0	710	2,2	980,0
700				On request
800				On request

## Ball valves with air vent(s)

**Standard:** EN 488

**Operating temperature:** max. +148 °C

**Operating pressure:** NP 25

The ends of each part are not insulated over a length of 150 mm.  
A monitoring system with detection wires can be supplied upon request.

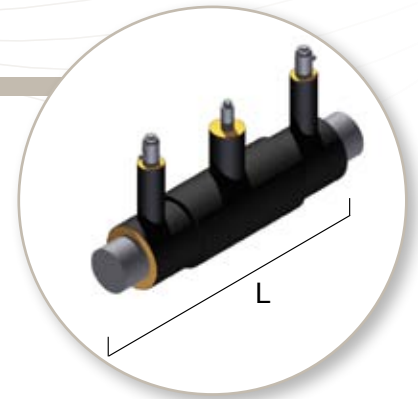

**Ball valves with air vents can be supplied with geared actuators.**  
**Inpal Energie recommends the use of geared actuators from ND 125.**

Steel pipe		Casing	Pre-insulated valve + 2 air vents		
ND	Ø Ext.	Ø Ext.	Length L	Vent valve	
mm	mm	mm	m	DN recom.	DN max.
20	26,9	90	1,5	20	20
25	33,7	90	1,5	25	25
32	42,4	110	1,5	25	25
40	48,3	110	1,5	25	32
50	60,3	125	1,5	25	40
65	76,1	140	1,5	25	50
80	88,9	160	1,5	25	65
100	114,3	180	1,5	25	80
100	114,3	200	1,5	25	100
125	139,7	200	1,5	25	100
125	139,7	225	1,5	25	100
150	168,3	250	1,5	32	100
200	219,1	315	1,5	32	100
250	273,1	355	2,1	32	100
300	323,9	400	2,1	32	100
300	323,9	450	2,1	32	100
350	355,6	450	2,1	32	100
350	355,6	500	2,1	32	100
400	406,4	500	2,1	32	100
450	457,0	560	2,8	32	100
500	508,0	630	2,8	32	100
600	610,0	710	2,8	50	100
700			On request		
800			On request		

## Injected junction kits

Various types of junction kits are available to fit with soil types and customer requirements.

**Standard:** EN 489

### Injected junction kit: i1

I1 injected junction kits are used to insulate the junctions of the network elements. They feature a quick and easy to use rigid muff.

**Composition of the i1 kit:**

- 1 HDPE sliding muff
- 2 heat-shrinkable sleeves,
- 2 vent plugs
- 2 closure plugs,
- 2 closure patches (FOPS)
- Pre-dosed PUR foam kit, 2 components

Insulation is obtained by mixing and pouring the polyurethane foam components into the junction on site.



1 HDPE sliding muff  
with 2 injection holes

2 heat-shrinkable sleeves

### Injected heat-shrink junction kit : i2

I2 injected junction kits are used to insulate the junctions of the network elements. They feature a quick and easy to use heat-shrinkable muff.

**Composition of the i2 kit:**

- 1 HDPE heat-shrinkable muff
- 2 vent plugs
- 2 closure plugs,
- 2 closure patches (FOPS)
- Pre-dosed PUR foam kit, 2 components.

Insulation is obtained by mixing and pouring the polyurethane foam components into the junction on site.



1 HDPE heat-shrinkable muff  
with 2 injection holes

## Injected heat-shrink junction kit: i3

I3 injected junction kits are used to insulate the junctions of the network elements. They feature a double seal.

### Composition of the i3 kit:

- 1 HDPE heat-shrinkable muff
- 2 heat-shrinkable sleeves
- 2 vent plugs
- 2 closure plugs,
- 2 closure patches (FOPS)
- Pre-dosed PUR foam kit, 2 components.

Weld-on plugs can be proposed on request. Insulation is obtained by mixing and pouring the polyurethane foam components into the junction on site.



1 HDPE heat-shrinkable muff  
with 2 injection holes

2 heat-shrinkable sleeves

## Bend insulation kit: i4

### Composition of the i4 kit:

- A flexible heat-shrinkable muff (angle between 0° and 90°).
- 1 90° steel bend to adjust on site
- 1 centerring
- 2 vent plugs
- 2 closure plugs,
- 2 closure patches (FOPS)
- Pre-dosed PUR foam kit, 2 components.

Insulation is obtained by mixing and pouring the polyurethane foam components into the junction on site.

**The i4 bend insulation kit is only available for casing diameters from 90 to 250 mm.**



1 HDPE heat-shrinkable muff  
with 2 injection holes

## Straight T-branch insulation kit : i7

17 kits are used to insulate straight T-branches.

### Composition of the i7 kit:

- 1 T-shaped HDPE muff
- 2 heat-shrinkable sleeves,
- 1 vent plug
- 1 closure plug,
- 1 closure patch (FOPS)
- Pre-dosed PUR foam kit, 2 components.

Insulation is obtained by mixing and pouring the polyurethane foam components into the junction on site.



1 T-shaped HDPE muff

2 heat-shrinkable sleeves

## Hot-tapping-valves insulation kit: i8

The i8 kit is used to insulate a hot-tapping-valve. It consists of two components with HDPE casing: A T-shaped base and a 45° bend, the two parts fitting into each other. The heat-shrinkable sleeves provided guarantee water tightness.

### Composition of the i8 kit:

- 1 T-shaped HDPE muff
- 1 HDPE bend muff section
- 1 HDPE reduced muff
- 5 heat-shrinkable sleeves,
- 1 centerring
- 1 steel pipe section
- 1 steel bend
- 1 vent plug
- 1 closure plug,
- 1 closure patch (FOPS)
- Pre-dosed PUR foam kit, 2 components.

Insulation is obtained by mixing and pouring the polyurethane foam components into the junction on site.



1 T-shaped sliding HDPE muff

1 45° bend sliding HDPE muff

The hot tapping-valve is not included in the kit. The hot-tapping-valve kit is available from ND 20 to ND 100.

Other diameters are available upon request.



## Injected electrowelding junction kit: i10

The i10 injected junction kit is used to insulate the junctions of the network elements.

Waterproofness is made by electrofusion between the muff and pipe casing and the i10 kit is recommended for difficult soil types.

### Composition of the i10 kit:

- 1 heat-shrinkable HDPE muff
- Fusion grids
- 2 vent plugs
- 2 closure plugs,
- 2 closure patches (FOPS)
- Pre-dosed PUR foam kit, 2 components.

Insulation is obtained by mixing and pouring the polyurethane foam components into the junction on site.



1 heat-shrinkable HDPE muff  
with 2 injection holes

Fusion grids

## Injected electrowelding junction kit: i20

The i20 junction kit provides the highest quality for network component junctions through the use of electrowelding and PE extrusion welding.

### Composition of the i20 kit:

- 1 HDPE muff to split
- Fusion grids
- 2 vent plugs
- 2 welding plugs
- Pre-dosed PUR foam kit, 2 components.

Insulation is obtained by mixing and pouring the polyurethane foam components into the junction on site.



1 HDPE muff to split

## Injected reducing kit: i6

### Composition of the i6 kit:

- 1 HDPE reduced muff
- 1 steel reduction
- 2 heat-shrinkable sleeves,
- 1 vent plug
- 1 closure plug,
- 1 closure patch (FOPS)
- Pre-dosed PUR foam kit, 2 components.

Reductions can cover up to 3 pipe diameters.

The i6 kit must be placed on the smaller diameter pipe casing before welding the pipes together.

Insulation is obtained by mixing and pouring the polyurethane foam components into the junction on site.



1 heat-shrinkable sleeve

1 HDPE muff with 1 injection hole

1 heat-shrinkable sleeve

## Injected end of line kit: i5

Injected end of line kits are used when the pre-insulated pipes are left waiting for a future connection.

### Composition of the i5 kit:

- 1 HDPE end muff
- 1 steel cap
- 1 heat-shrinkable sleeve
- 1 vent plug
- 1 closure plug,
- 1 closure patch (FOPS)
- Pre-dosed PUR foam kit, 2 components.

**Weld-on plugs can be proposed on request.**

Insulation is obtained by mixing and pouring the polyurethane foam components into the junction on site.



1 HDPE end muff  
with 1 injection hole

1 heat-shrinkable sleeve



## Half-shell junction kits

### Half-shell shrinkable sleeve kit: C1

The C1 half-shell junction kit is used to insulate the junctions of the network elements.

The C1 kit can be installed after welding the network components together.

**Composition of the C1 kit:**

- 2 half-shells
- 1 protective film
- 1 heat-shrinkable sleeve of 650 mm width

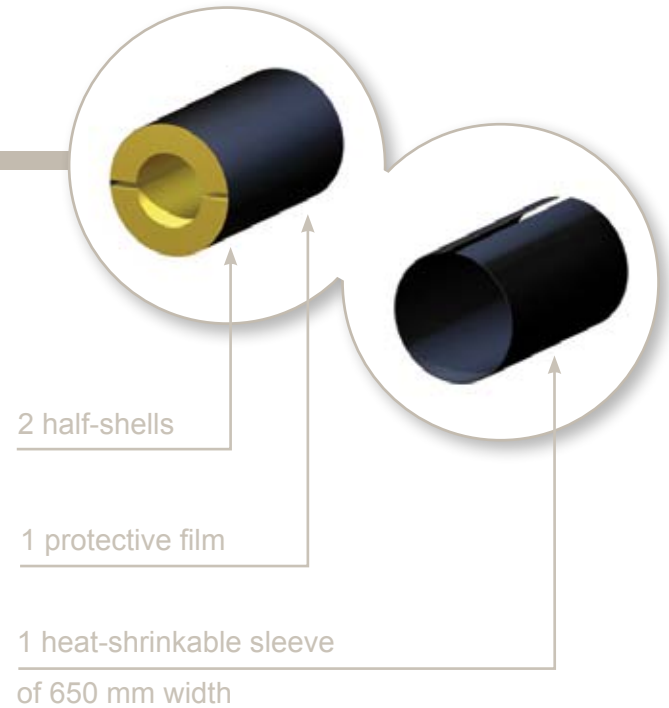

### Half-shell shrinkable junction kit: C2

The C2 half-shell junction kit is used to insulate the junctions of the network elements.

The C2 kit can be installed after welding the network components together.

**Composition of the C2 kit:**

- 2 half-shells
- 1 protective film.
- 1 heat-shrinkable HDPE muff

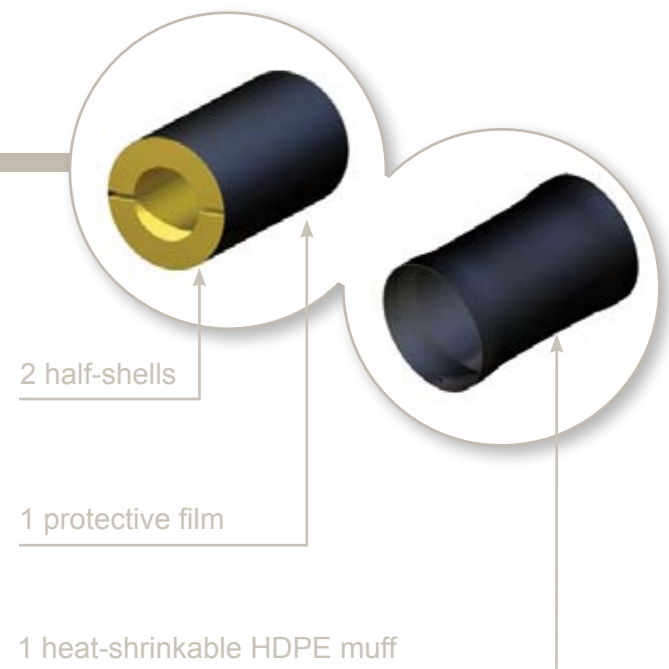

## Half-shell end-of-line kit: C5

The C5 end-of-line kit is used when the pre-insulated pipes are left waiting for a future connection.

### Composition of the C5 kit:

- 2 half-shells
- 1 protective film.
- 1 HDPE end muff

The steel cap is included in our supply.



## Half-shell kit for straight T-branches: C7

The C7 half-shell kit is used to insulate T-branches made on site.

### Composition of the C7 kit:

- 4 half-shells
- 1 T-shaped HDPE muff
- 2 heat-shrinkable HDPE sleeves



# District Heating End Cap: DHEC



The District Heating End Cap (DHEC) is a heat-shrinkable part made from cross-linked polyolefins. It is coated inside with an adhesive. The DHEC was developed to seal the cut end of the polyurethane foam insulation between the main pipe and the outer casing, on pre-insulated pipe networks.

The DHEC must be placed on the pipe casing before welding the pipes together.

A DHEC must be used at each interruption of the pre-insulated network (valve chamber, entering buildings, etc.) to prevent water ingress inside the insulation.

## Protection

If the outer casing is damaged or leaks, DHEC limit damage to the insulation, preventing it from spreading along the network.

## Adaptation

DHEC is designed so that it can be installed on a very wide range of pipe diameters and insulation thicknesses. Special dimensions can be produced upon request.

## Financial advantages

DHEC can be installed in just a few minutes. The end caps prevent damage to the insulation, thereby minimising repair costs.

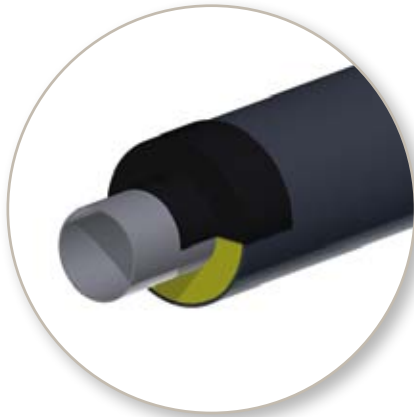

DHEC  
up to ND 350/450  
(steel/casing)

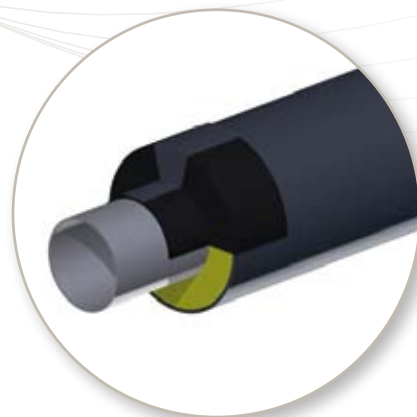

CCS-DHEC (zipper-closed)  
from ND 350/500  
(steel/casing)

Steel pipe		Casing	DHEC
ND	Outer Ø	Outer Ø	Type
mm	mm	mm	
20	26,9	90	2000
25	33,7	90	2100
32	42,4	110	2200
40	48,3	110	2300
50	60,3	125	2400
65	76,1	140	2400
80	88,9	160	2500
100	114,3	180	2600
100	114,3	200	2600
125	139,7	200	2630
125	139,7	225	2630
150	168,3	250	2700
200	219,1	315	2800
250	273,1	355	2900
300	323,9	400	3000
300	323,9	450	3000
350	355,6	450	3000
350	355,6	500	560/273
400	406,4	500	560/273
450	457,0	560	560/273
500	508,0	630	710/355
600	610,0	710	710/355
700	711,0	900	900/457
800	813,0	1000	1200/610



## Wall crossing

Wall crossing is rubber seals used to connect all types of pipe on manholes, buildings or other concrete structures .

Wall crossing is installed as a barrier against water penetration. It allows small expansion movements at this point.

Wall crossing is made from SBR (styrene butadiene rubber), hardness  $40 \pm 5^\circ$  IHR (indicative value). It must be used at every feedthrough (valve chamber, entering buildings, etc.) so that the pre-insulated pipe can expand through the wall without damage.

For special cases, we propose suitable wall crossing solutions featuring optimum sealing.





Up to HDPE diameter 250



From HDPE diameter 300

Steel pipe		Wall crossing		
ND	Outer Ø	A	A'	B
mm	mm	mm	mm	mm
20	90	22	12	50
25	90	22	12	50
32	110	22	12	50
40	110	22	12	50
50	125	22	12	50
65	140	22	12	50
80	160	22	12	50
100	180	22	12	50
100	200	22	12	50
125	200	22	12	50
125	225	22	12	50
150	250	22	12	50
200	315	22	12	50
250	355	22	12	50
300	400	22	22	50
300	450	22	22	50
350	450	22	22	50
350	500	22	22	50
400	500	22	22	50
450	560	22	22	50
500	630	22	22	50
600	710	22	22	50
700	900	22	22	50
800	1000	22	22	50
900	1100	22	22	50
1000	1200	22	22	50

# Expansion pads

Expansion pads are used on bends and branches where lateral movements need to be absorbed.

Pads allow the buried network to expand freely.

The maximum expansion movement absorbed per pad layer is 30 mm. A maximum of 3 pad layers can be used per part.

Expansion pads consist of flexible polyolefin foam. The density is 28 kg/m<sup>3</sup>. The size of the pads depends on the outer casing dimensions.

### Implementation:

The expansion pads are positioned on the HDPE casing and must be held on pipe before backfilling, to prevent sand between the casing and the pads.

A special system with polyester large strip is available upon request.

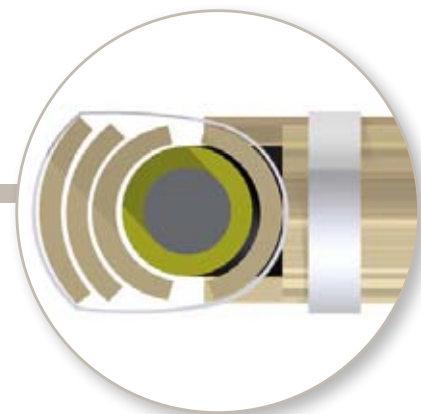

### Number of pads depending on the expansion

Deflection arm	Expansion	Expansion	Expansion
L	$\Delta L < 30 \text{ mm}$	$\Delta L 30 - 60 \text{ mm}$	$\Delta L 60 - 90 \text{ mm}$
m	Pce	Pce	Pce
1,0 - 1,4	1	1 + 1	
1,5 - 2,4	2	2 + 1	
2,5 - 3,4	3	3 + 2	3 + 2 + 1
3,5 - 4,4	4	4 + 3	4 + 3 + 2
4,5 - 5,4	5	5 + 4	5 + 4 + 2
5,5 - 6,4	6	6 + 4	6 + 5 + 4
6,5 - 7,4	7	7 + 5	7 + 6 + 4
7,5 - 8,4	8	8 + 6	8 + 7 + 5
8,5 - 9,4		9 + 6	9 + 7 + 5
9,5 - 10,4		10 + 7	10 + 8 + 6
10,5 - 11,4			11 + 9 + 7



**Pad dimensions depending on the casing :**

There are 4 different models of pads :

- 120 x 1000 mm
- 240 x 1000 mm
- 360 x 1000 mm
- 1000 x 2000 mm (to cut to desired length)

Model pads selected depend on the size of the casing and is shown in the table :

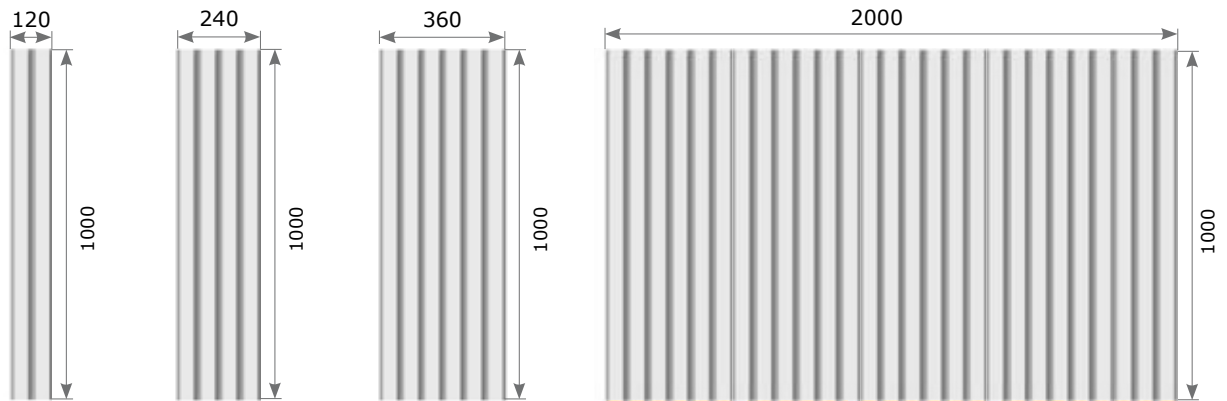

Casing Outer Ø mm	Pads				Modèle
	L mm	Wall thickness mm	H mm		
90	1000	40	120		I
110	1000	40	120		I
125	1000	40	120		I
140	1000	40	120		I
160	1000	40	120		I
180	1000	40	240		II
200	1000	40	240		II
225	1000	40	240		II
250	1000	40	240		II
280	1000	40	240		II
315	1000	40	360		III
355	1000	40	360		III
400	1000	40	480		II + II
450	1000	40	480		II + II
500	1000	40	480		II + II
560	1000	40	600		II + III
630	1000	40	720		III + III
710	1000	40	840		III + II + II
800	1000	40	960		III + III + II
900	1000	40	1080		III + III + III
1000	1000	40	1200		III + III + II + II
1200	1000	40	1440		III + III + III + III

# Monitoring systems

It is essential for all heating or cooling network operators to anticipate the risks of leaks and therefore damage.

The solution is to install a system to monitor your pre-insulated network using alarm wires included in the insulation of pipes and accessories.

This process can be used to **detect** abnormal humidity in the insulation and/or locate the fault. These monitoring systems can be used to accurately **check** several kilometres of pre-insulated network.

## System with Ni-Cr wires (Nickel-Chromium)

**Standard** : EN 14419

**Electrical resistance** : 5.7  $\Omega$  /meter

**Maximum wire length** : 1000 m

**Connection** : Electrical loop

The monitoring system consists of:

- 1 red insulated nickel chromium "**sensor**" wire, stripped every 1.5 cm
- 1 green insulated copper "**ground**" wire

The system is based on the quantity of electricity conducted by the insulation, which varies depending on its humidity.

Depending on the amount of moisture of the polyurethane foam, the electrical resistance between the service pipe and the foam decreases.

Humidity can be located by measuring the resistance.

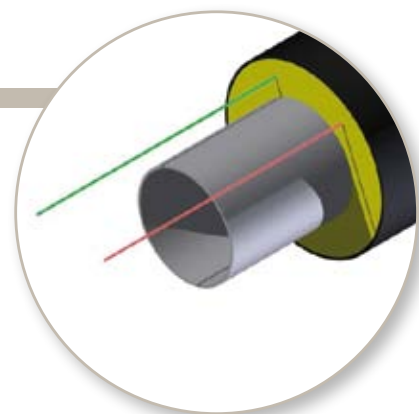

*Detection unit  
reference 8000*

System composition

1 Ni-Cr wire with Teflon casing (sensor)		1 copper wire with Teflon casing (return)	
Inner Ø	Outer Ø	Inner Ø	Outer Ø
mm	mm	mm	mm
0,6	1,1	0,9	1,4

## System with copper wires

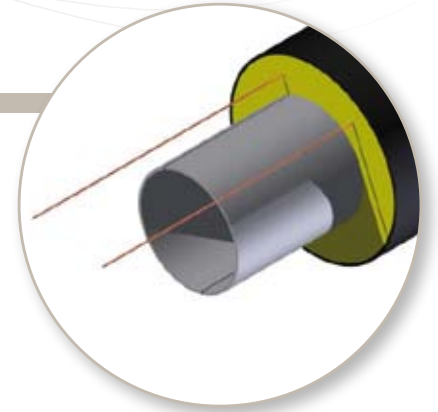

**Standard** : EN 14419

**Electrical resistance** : 24  $\Omega$  /meter

**Maximum wire length** : 7000 m in detection and 2500 m in location

**Connection** : Electrical loop or single wire

The monitoring system consists of:

- 1 "sensor" bare tin-plated copper wire
- 1 "return " bare copper wire

System composition	
1 bare tin-plated copper wire	1 bare copper wire
$\varnothing$ mm	$\varnothing$ mm
1,39	1,39

The system is based on the quantity of electricity conducted by the insulation.

Depending on the amount of moisture of the polyurethane foam, the electrical resistance between the service pipe and the foam decreases.

Humidity can be detected by measuring the impedance.

The units are available in several models:

- Detectors indicate the presence of faults on the network.
- The locator can detect faults on the network and locate the leak to allow targeted interventions.

Connection	Detection			Detection and location
	Loop	single wire		
Unit model	2020	2020	3000	4000
				
Wire length (linear metres)	2 x 7000	2 x 7000	4 x 1000	4 x 2500

# Network Geolocation system

To protect your investment in the long term, simplify the creation of your as-built drawings and allow traceability throughout the lifetime of your installation, **Inpal Energie** proposes a network geolocation system called **IGEO**.

The system consists of markers (spheres or plates) positioned at strategic points on your network.



Specifications	
Memory	<ul style="list-style-type: none"> <li>• Unique identification number</li> <li>• Memory reinscriptable &gt;1000 times</li> <li>• Data retention = 100 years</li> <li>• 6 labels + 6 descriptions</li> <li>• Autonomous : no power supply required</li> </ul>
Writing, reading and depth	<ul style="list-style-type: none"> <li>• Writing available up to 45 cm distance with the assistance of a detector</li> <li>• Reading available up to 2,80 m maximum</li> </ul>
Environment	Anti-freezing liquid with no environmental impact

### The markers are used to identify:

- The network layout
- The network special components (bends, tee-branches, bellows, valves, etc.)
- The depth of the pipes installed
- Various strategic positions (e.g.: network crossing)



The data required to locate the network is recorded via a **GPS** associated with a **detector**.

## The location of your

1

Data gathering for recording and solution proposal



2

Creation of data fields and recording. Installation of the buoys in strategic areas

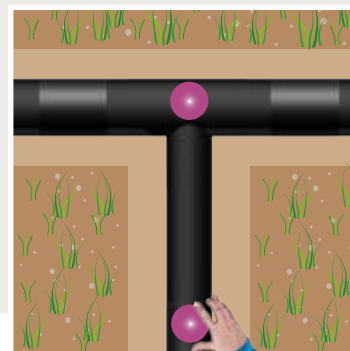



The following information can be retrieved:

- The **Geographical coordinates** of the marker  
(Longitude/Latitude)
- Its **depth**
- The unique **identification number**
- Other **data already programmed** in the marker:

- Nominal diameter
- Fluid temperature
- Application type (heating, steam, etc.)
- Pressure
- Implementation date

Once the markers have been programmed, the information entered and the data retrieved, you can:

- Produce the as-built drawing using **CAD software**
- Export data via **Google Earth**
- Store all your data

We offer a customised service that includes:

- Supply of the system.
- Programming of the RFID chips.
- Positioning of the markers on the networks.
- Recording and transmission of GPS coordinates

### Options

- Positioning of GPS coordinates on the network drawing
- Data gathering using Google Earth
- Secure data storage

## Advantages

- A turnkey service : Study / Equipment / Installation / Maintenance
- Multi-data storage
- A reliable, robust and independent system
  - Marker shells made from polyethylene
  - Power free system (activation via the detector)
- Precise detection
- A system which respects the environment

## network step by step

3

Data recording on GPS assisted by a detector

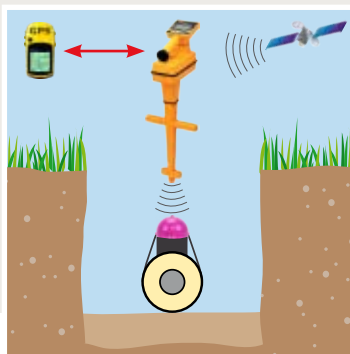

4

Data transfer and processing via Google Earth or any CAO software







# References

- 50 Zona Franca - Barcelona
- 51 Expo'98 - Lisbon
- 52 La Thuile - Italy
- 53 Climespace - Paris
- 54 London Olympic Site
- 55 22@ - Barcelona
- 56 Antwerp - Belgium

## Zona Franca - Barcelona

- **Customer:** DALKIA
- **Project:** 2011 - Spain
- **Operating conditions:**  
Chilled water: 12 °C – 5 °C - max. 6 bar  
Hot water: 90 °C – 70 °C - max. 6 bar
- **Supply:**  
PU130- ND 50 to 800 - in 6 m and 12 m lengths.
- **Main pipe:**  
Welded black steel tube, length according to EN 10217
- **Insulation:**  
Polyurethane foam –  $\Lambda < 0.027 \text{ W/(m x K)}$
- **Outer casing:** High-density polyethylene

The Barcelona Zona Franca, and more precisely the Poligon Industrial, is a logistics area undergoing extensive redevelopment further to the closure of a SEAT factory.

Located between Barcelona port and the airport, it offers excellent industrial potential and extensive development possibilities.

Dalkia Contracting, a subsidiary of Dalkia Spain, is currently building on this site a 3 mio MWh to supply, through the operator Ecoenergies Barcelona, hot, cold and glycolated water to companies set up in the area and to the nearby exhibition centre.

To build the distribution network, Dalkia selected our Spanish subsidiary INPAL Energía and COPISA, a renowned Catalan construction company.

The UTE INPAL/COPISA is responsible for the supply and installation of 80% of the network, which is more than 7 km long.

On the remaining 20%, outside the plant, the group is also responsible for the earthworks with trenches up to 4.50 m deep.





# Expo '98 - Lisbon

- **Customer:** CLIMESPACE - ELYO
- **Project:** 1998 - Portugal
- **Operating conditions:**  
Chilled water: 4 °C – 12 °C - max. 15 bar  
Hot water: 100 °C – 70 °C - max. 15 bar
- **Supply:**  
Polyuretub 130 - ND 50 to 800 - 12 m lengths
- **Main pipe:**  
Welded black steel tube, length according to NFA 49142
- **Insulation:**  
Polyurethane foam –  $\Lambda < 0.027 \text{ W}/(\text{m} \times \text{K})$ .
- **Outer casing:** High-density polyethylene

More than 3500 junction insulation kits.

Started in March 1996, the Lisbon Universal Exhibition work site was completed in April 1998.

The first European tri-generation plant initially served the 60 hectares covered by the exhibition.

In 2010, it was extended to the 350 hectares site converted into an urban area designed to accommodate 25,000 inhabitants and 18,000 jobs.

This plant develops a maximum power of 90 MW in air-conditioning and 44 MW in heating. 42 kilometres of Polyuretub 130 pre-insulated pipes were supplied to run between the plant and the 70 buildings erected on the site.

In 24 months, INPAL Energie delivered 192 lorries to supply the work site with the pipes and accessories that will be laid buried and in technical galleries.

The concession company for the heating and cooling networks for a period of 25 years, Climaespaço, a subsidiary of Elyo, Climespace, GDF International and RAR Ambiente, operates the network.



## La Thuile - Italy

- **Customer:** City of La Thuile
  - **Project:** 2009/2010 - Italy
  - **Operating conditions:**  
Hot water: 90 °C – 75 °C - max. 10 bar
  - **Supply:**  
Polyuretub 130 - ND 50 to 300 - 12 m lengths
  - **Main pipe:**  
Welded black steel tube, length according to EN 10217
  - **Insulation:**  
Polyurethane foam –  $\text{Lambda} < 0.027 \text{ W}/(\text{m} \times \text{K})$
  - **Outer casing:** High-density polyethylene
- Installation of a humidity detection system

INPAL Energia S.r.l. built the heating network for the Town of La Thuile.

The network is supplied by a biomass plant and an ORC (Organic Rankine Cycle) installation for the production of heat and electricity.

Between 2009 and 2010, INPAL Energia s.r.l. supplied 8 kilometres of Polyuretub 130 pre-insulated pipes and accessories.



# Climespace - Paris

- **Customer:** CLIMESPACE
- **Project:** 2009 - France
- **Operating conditions:**  
Iced water: 4 °C – 14 °C - max. 16 bar
- **Supply:**  
Polyuretub 130 - ND 500 - 12 m lengths
- **Main pipe:**  
Welded black steel tube, length according to EN 10217
- **Insulation:**  
Polyurethane foam –  $\Lambda < 0.027 \text{ W/(m x K)}$
- **Outer casing:** High-density polyethylene

300 bends installed  
800 junction insulation kits

Concession company for the City of Paris since 1991, CLIMESPACE produces and distributes cold energy for air-conditioning.

Over the last 18 years, INPAL Energie has supplied a large proportion of the 70 km long network installed in the drains or buried underground.

The main "Centre" network extends over the 1st, 2nd, 7th, 8th, 9th and 16th arrondissements. "Bercy", a secondary independent network, is located in the 12th and 13th arrondissements. Most of this underground network is installed in the sewerage structures of the City of Paris or runs under the roads. 85% of the network can therefore be inspected.

Regular and daily checks are performed on this fully-meshed, interconnected network. CLIMESPACE has entered a cycle where the new work phase is accompanied by a network operation ramp-up.

In 2009, 1,860 metres of ND 500 were laid, Boulevard Saint Germain. The installers for this project were COFELY Installation and SADE.





## London Olympic site

- **Customer:** COFELY
- **Project:** 2008/2009 - London
- **Operating conditions:**  
Hot water: 100 °C – 80 °C – max. 10 bar  
Chilled water: 8 °C – 2 °C – max. 16 bar
- **Supply:**  
PU130- ND 32 to 700 - in 12 m lengths
- **Main pipe:**  
Welded black steel tube, length according to EN 10217
- **Insulation:**  
Polyurethane foam –  $\Lambda < 0.027 \text{ W/(m x K)}$
- **Outer casing:** High-density polyethylene

Inpal Energie designed, manufactured and supplied a network of more than 26 kilometers of Polyuretub 130 pre-insulated pipes, intended for the heating and air-conditioning of the London Olympic site.

This ambitious work site, carried out on behalf of COFELY (GDF-Suez Group), the company responsible for the operation of the site's future networks, started in 2008.

Thanks to our expertise and the high performance of Polyuretub 130 pipes, we were able to propose a sustainable energy solution for these sports installations.

Two tri-generation stations (production of heat, air-conditioning and electricity) fuelled with natural gas and biomass will supply our networks with low CO<sub>2</sub>-emission heating and air-conditioning energy.

These two plants will produce about 86 MW for heating, 20 MW for air-conditioning and will cater for more than 75% of the site's electricity requirements.

In less than 12 months, INPAL Energy will have delivered more than 3,500 pre-insulated parts (pipes and accessories) in 150 lorries for this project.



## 22@ - Barcelona

- **Customer:** DISTRICLIMA
- **Project:** 2005/2007 - Spain
- **Operating conditions:**  
Chilled water: 6 °C – 12 °C - max. 13 bar  
Hot water: 110 °C – 75 °C - max. 15 bar
- **Supply:**  
Polyuretub 130 - ND 50 to 800 - 12 m lengths
- **Main pipe:**  
Welded black steel tube, length according to EN 10217
- **Insulation:**  
Polyurethane foam –  $\Lambda < 0.027 \text{ W/(m x K)}$
- **Outer casing:** High-density polyethylene

22@ was the first district of Barcelona to be equipped with centralised air conditioning :

- A public service to companies covering up to 70% of demand in the district.
- A project which generated 40% energy savings.

During the Forum of Cultures in 2004, the Besos air conditioning plant was created to supply the main buildings in this district.

The possibility of extending the network then became possible. Disticlima built the network after being awarded a public tender.

This operation was carried while new companies were being set up in the area in order to adapt the supply to the demand.

A second auxiliary station was then built in the Audiovisual Park and connected to that of the Forum already in operation.

This second installation used the chimney of the former factory to link the future to the "Manchester Catalan" heritage.

Between 2005 and 2007, INPAL Energie supplied 16 kilometres of Polyuretub 130 pre-insulated pipes.



## Antwerp - Belgium

• **Customer:** THV LOCOBOW

• **Project:** 2012 - Belgium

• **Operating conditions:**

Ice water : -28°C – 10 Bar

Brine: -28 °C – 10 bar

• **Supply:**

Polyuretub M - ND 200 - 6 m lengths

• **Main pipe:**

Welded black steel tube, length according to EN 10217-4 P265N

Grooved for assembly by mechanical collar

• **Insulation:**

Polyurethane foam, fire classification (M1)

Lambda < 0.030 W/(m x K).

• **Outer casing:**

Spiral galvanised steel Ø 400 mm (Insulation ++)

A new underground railway line about 16 km long is being built in the port area of Antwerp (Belgium) to optimise the transit of goods.

THV Locobouw was selected to execute the project.

INPAL Energie was contacted at end 2009 to provide a solution for the transport of brine (calcium chloride) at -28°C over a distance of 4 km.

To ensure fast installation time, as a replacement for a traditional assembly of welded pipes, unsuitable for tunnels, INPAL Energie proposed the supply of mechanical assembly collars.

INPAL pipes will only be used during the period of the work site, since the fluid they transport is intended exclusively to freeze the ground in order to excavate secondary galleries, between tunnel A and tunnel B.

The tunnel excavation is scheduled to end in 2012. INPAL Energie supplied 4 kilometres of Polyuretub M pre-insulated pipes.









Solutions for  
energy efficiency

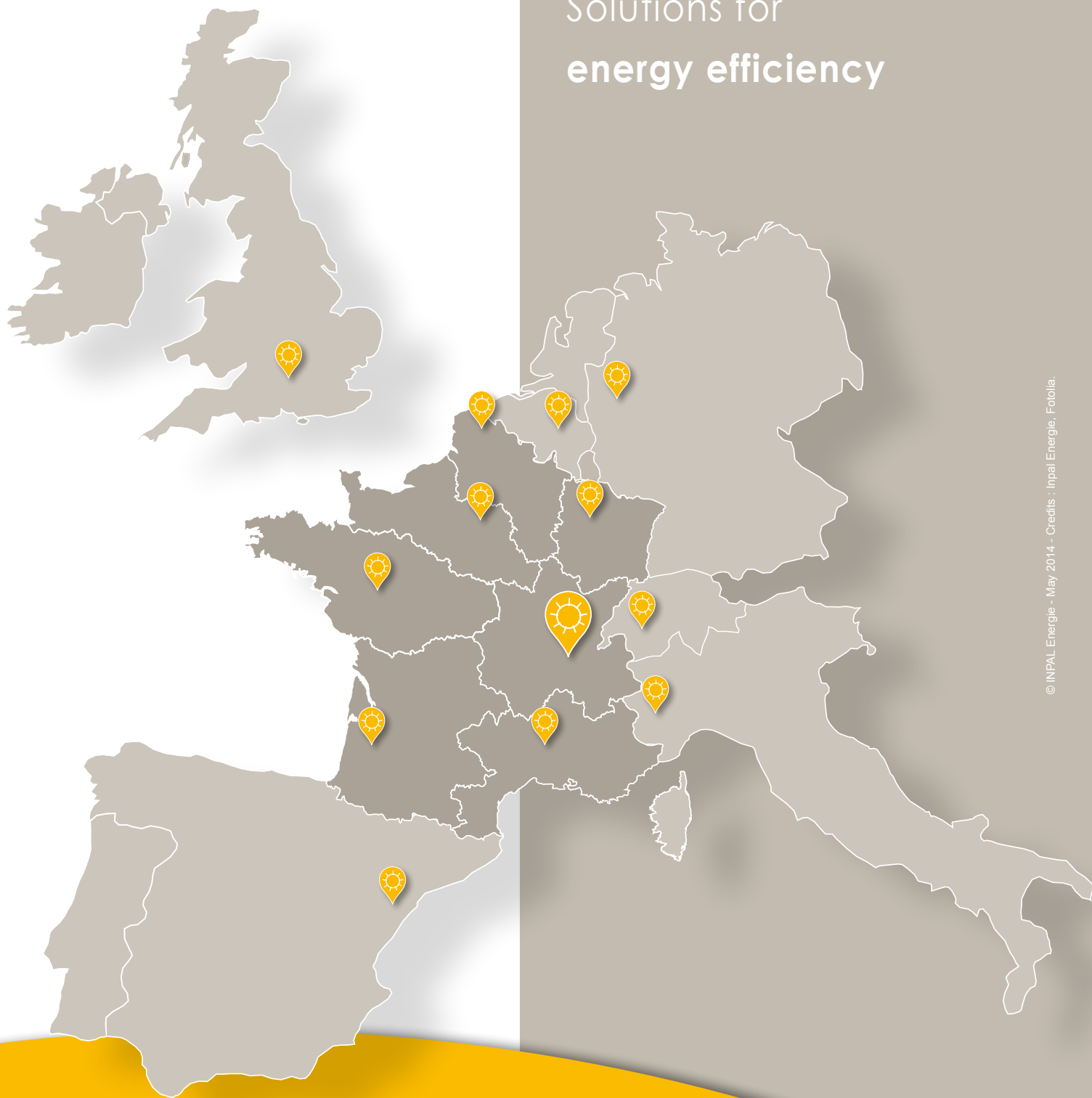

© INPAL Energie - May 2014 - Credits : Inpal Energie, Fotolia.

## **Inpal Energie**

238, rue des Frères Voisin  
ZAC Chapotin - 69970 Chaponnay - France  
Tél. : +33 (0)4.78.69.63.20 - Fax : +33 (0)4.72.71.89.52  
[accueil@inpal.com](mailto:accueil@inpal.com) - [www.inpal.com](http://www.inpal.com)